

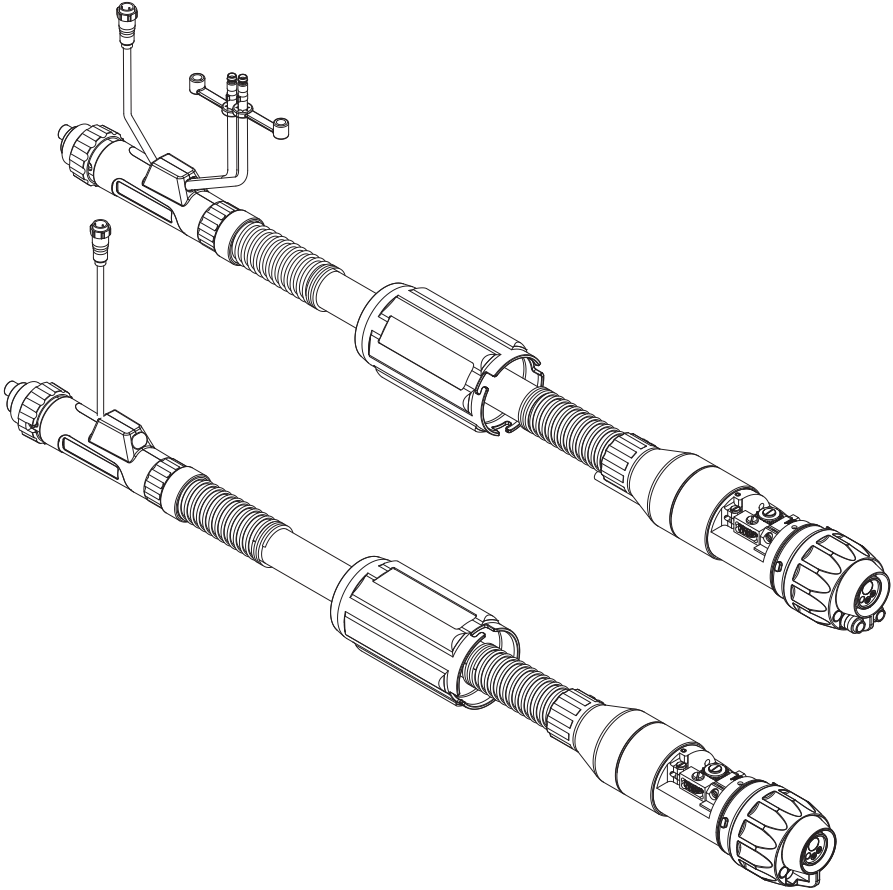

MECHAFIN

Welding accessories - Swiss Quality

Operating Instructions for Mechafin PushPull



MECHAFIN AG has the right to make changes to the operating manual without prior notice, which may be necessitated due to printing errors or potential neglect of the information contained therein, or further product development. Any changes will then be listed in newer editions.

Content

1.	Assessment	2
1.1.	EU Declarations of Conformity	2
1.2.	Manufacturer's obligations	2
2.	Product description	2
2.1.	Product description	2
2.2.	Intended use	2
2.3.	Technical data	3
3.	Safety instructions	4
3.1.	Essential safety instructions	4
3.2.	General safety instructions	4
3.3.	Specific hazard instructions	5
3.4.	Technical condition	5
3.5.	Characterisation	5
4.	Delivery contents	5
4.1.	Transport	5
5.	Function	6
5.1.	MIG/MAG welding torch	6
6.	Commissioning the intermediate drive	6
6.1.	Preparation for welding	7
6.2.	Connecting	7
6.3.	Introducing wire	8
6.4.	Opening/closing the pressure arm	8
6.5.	Changing the feed roller	9
6.6.	Exchanging the wire guide	9
6.7.	Exchanging the wire liner	10
6.8.	Coolant (this is only required for liquid-cooled welding torches.)	11
6.9.	Setting the shielding gas quantity	11
6.10.	Application	11
7.	The control unit	12
7.1.	Overview	12
7.2.	Technical data	12
7.3.	Pin assignment	13
7.4.	Operation of the control unit	13
7.5.	Operation overview	14
7.6.	Program modes	16
7.7.	Commissioning the intermediate drive with the control unit	20
7.8.	Calibration process of the control unit during commissioning	20
7.9.	Fastening the control unit	21
7.10.	Connecting the intermediate drive for welding	22
7.11.	Starting the welding process	23
8.	Operation	23
9.	Maintenance I Cleaning	24
9.1.	General information	24
9.2.	Hose pack	24
9.3.	Wire liner	24
10.	Disassembly and disposal	25
11.	Emergency	25
12.	Warranty	25
13.	Faults and how to remedy them	26
14.	Accessories and wear parts	27
15.	Length recommendation for the PUSH PULL	28



1. Assessment

The MECHAFIN AG intermediate drive is exclusively intended to weld with shielding gas. Welding can be carried out with inert gases (MIG), or active gases (MAG). The intermediate drive is intended for industrial and commercial use. It is available as gas or liquid cooled. A cooling unit is required for the liquid-cooled welding torches. The welding torches should only be operated with original MECHAFIN AG spare parts.

1.1. EU Declarations of Conformity

In accordance with EC Low-Voltage Directive 73/23/EEC, Appendix 111, we

MECHAFIN AG
Chrummacherstrasse 3
8954 Geroldswil
Switzerland

hereby declare, that the intermediate drive described, on account of its construction and design, as well as the version that we have put on the market, comply with the EC Directive's relevant essential health and safety requirements. This declaration will become void if changes are made to the intermediate drive that have not been agreed with us.

Harmonised standard used:
DIN EN 60 97 4-7 Light arc welding devices; Part 7 Torches

1.2. Manufacturer's obligations



National implementation of the Framework Directive (89/391/EEC), as well as the associated individual Directives, particularly the Directive on the minimum requirements for health and safety when contractors use equipment at work (89/655/EEC) as amended, must be observed and adhered to. The Occupational Health and Safety Act and the Ordinance on Industrial Health and Safety must be observed. The operator must also ensure that the wire feed system complies with EC Directive EMC (89/336/EEC) in conjunction with welding devices, and that signal exploitation is installed from the built-in welding current monitoring system against surface leakages so the power source can switch off safely.

2. Product description

2.1. Product description

Depending on the design, MECHAFIN AG MIG/MAG welding torches are gas or liquid-cooled. The hose pack of the intermediate drive is geared towards the respective torch cooling system. All elements form a functional unit.

2.2. Intended use

Overburdening the intermediate drive or improper use is prohibited. Observing the prescribed operating, maintenance and servicing conditions is also part of intended use. Wear and damage that can be attributed to overloading or improper use are not covered by the warranty.



2.3. Technical data

General data (operating conditions)

Voltage type:	DC voltage
Electrode polarity:	usually positive
Wire types:	All commercially-available round wires
Guide type:	machine-guided
Voltage calculation:	113 V peak value, 141 V peak value
Protection type on the machine side	
Connections (EN 60 529):	IP3X, IP2X
Shielding gas:	CO2 or mixed gas M21 according to DIN EN 439
Hose packs:	
Standard length L:	5.00m; 10.00m; 15.00 m; 20.00m; 25.00m
Coolant connection:	Push-on nipple size NW 5
Cooling unit output:	min. 800 to 1000 W
Standard control line:	2-wire

Model-specific data

Item number	Cooling	Connection	for welding wire	Wire Ø [mm]	Length [m]
119864	Liquid	Euro	Steel	1.2	5.0
117218	Liquid	Euro	Steel	1.2	10.0
117219	Liquid	Euro	Steel	1.2	15.0
117217	Liquid	Euro	Steel	1.2	20.0
117220	Liquid	Euro	Steel	1.2	25.0
119915	Liquid	Euro	Aluminium	1.2	5.0
117215	Liquid	Euro	Aluminium	1.2	10.0
117216	Liquid	Euro	Aluminium	1.2	15.0
118458	Gas	Euro	Steel	1.2	5.0
117208	Gas	Euro	Steel	1.2	10.0
117209	Gas	Euro	Steel	1.2	15.0
117210	Gas	Euro	Steel	1.2	20.0
117211	Gas	Euro	Steel	1.2	25.0
119916	Gas	Euro	Aluminium	1.2	5.0
117204	Gas	Euro	Aluminium	1.2	10.0
117205	Gas	Euro	Aluminium	1.2	15.0

Attention: these products exclusively concern the PushPull.

The control unit must be ordered separately.

You will find the list with the control units and corresponding parts on page 27.



3. Safety instructions

WARNING / CAUTION

A potentially hazardous situation is described here. If this is not reported, serious injuries and material damage may result.

NOTE

A potential hazard is described here which indicates impaired work results and potential damage to the equipment.

IMPORTANT

Describes usage tips and other helpful information.
This is not a signal for dangerous or harmful situations.

3.1. Essential safety instructions

This operating manual explains information to the user that is required for flawless and safe operation.

NOTE

No liability will be assumed by MECHAFIN AG if there is any material damage due to disregard of the operating manual.

3.2. General safety instructions

- The operating manual must be diligently read and followed before work due to commissioning, operation or transport.
- The operating manual must be provided with the product for reference. The operating manual must be handed on when the product is passed on.
- The operating manuals of welding components such as welding power sources or wire feeding units must also be observed.
- For gas cylinder handling, please refer to the gas manufacturer's or supplier's instructions, and the compressed gas regulation.
- The respective country's accident protection regulations must be observed.
- Operating and maintenance work may only be carried out by specialists. A specialist is a person who, due to their training, experience, skills and knowledge of relevant standards, can assess work carried out by third parties and recognise potential hazards.
- Suitable fire protection equipment must be present at the workstation.

3.3. Specific hazard instructions

- Eye, skin and hearing damage may occur during light arc welding! Protective work wear must always be worn for eye, skin and hearing protection according to the respective country's relevant regulations.
- Metal vapours that occur are very harmful, especially with lead, cadmium, copper and beryllium!
- Adequate ventilation or extraction must be ensured during welding. Specified MAC values (max. allowable concentration) may not be exceeded.
- Work pieces that have been cleaned with chlorinated solvents or degreased should be rinsed with clear water, otherwise there is a risk of gasification.
- A greasing bath containing chlorine should not be set up in proximity to the welding area.
- Other hazards may occur when using welding torches such as those due to electric current (power source, internal circuit), welding spatter as a result of flammable or explosive substances, UV radiation due to the light arc, smoke and vapours.
- The intermediate drive must always be used when it is closed.
- The housing is made of aluminium and carries the welding voltage. Although it is in the safe low voltage range, the device must not be operated by pacemaker patients.
- The drive wheels have a strong torque and can injure fingers. Do not reach into the open wheels.
- When working on the intermediate drive, switch the welding unit off if possible.

3.4. Technical condition

- The specified performance data are the maximum determined limit values.
- Any overloading leads to destruction and thus grossly negligent destruction.
- It is forbidden to make physical changes without discussing them with the manufacturer.
- Use suitable protection against weather influences during outdoor use.

3.5. Characterisation



The following information is important for all queries:

- Labelling on connection housing on the machine side
- Visible item numbers or serial numbers
- Production stickers on the housing

4. Delivery contents

All intermediate drives are delivered fully assembled and checked ready for connection and operation.

- Intermediate drive
- Operating manual



NOTE

For order numbers and item numbers of equipment and wear parts, please refer to the order documentation. Check that the equipment parts are correct for initial fitting.

4.1. Transport

The product is always diligently checked and carefully packed before dispatch. However, damage occurring during transport cannot be excluded.

Incoming control

Always check that the delivery contents are complete using the delivery note.

In the event of damage

Always check the delivery contents for damage via a visual check.

In the event of any complaints

If the delivery has been damaged during transport, get in touch with the forwarder immediately. Keep the damaged packaging and the damaged delivery contents in case they are checked by the forwarder. Document the damage, preferably with photos.

Packaging for returns

If possible, please use the original packaging and the original packaging material. If you have any questions about the packaging or transport safety devices, get in touch with the supplier.

Storage in an enclosed room

CAUTION

Material damage

- Coolant that is still in the hose may freeze and damage the hose in the event of frost.
- It must be ensured that coolant is no longer present in the hoses in the event of frost.

Ambient air temperature during transport and storage: - 25°C to + 55°C

Relative humidity: up to 90% at 20°C

5. Function

The MIG/MAG intermediate consists of the following parts:

- Unit (push-pull system)
- Hose pack
- Control unit (plus cable)

5.1. MIG/MAG welding torch

Wires made of steel, aluminium, copper, nickel and stainless steel are conveyed through the welding system for welding. The wires can be filling wires or solid wires. The light arc and the weld pool are protected by inert gas (MIG) and active gas (MAG). The wires are conveyed by the contact tips. In this case, the contact tip transfers the welding current to the wires. The light arc forms between the wire and workpiece. The welding torches are either gas-cooled or liquid-cooled, and the hose pack has also been designed accordingly.

6. Commissioning the intermediate drive

DANGER

Risk of injury

In the event of inadvertent start-up, during maintenance, installation or repair work.

Always take the following precautionary measures for the entire duration of the work:

- Pull out mains plug
- Shut off gas supply
- Switch off the power source

6.1. Preparation for welding

Before commissioning, make sure that the liner that matches the wire is inserted (Chapter 6.7). Please replace if necessary. The wire guide must also fit (Chapter 6.6).

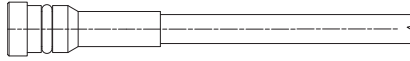

NOTE

New wire liners or plastic wire guides must always be adapted to the hose pack.

Are the correct feed rollers used? If not, proceed according to (Chapter 6.5).

6.2. Connecting

Connect the hose pack of the intermediate drive to your wire feeder with a Euro plug (just like the welding torch). Connect the two water connections (for the water-cooled intermediate drive) correctly. Connect the motor / encoder plug with the corresponding connector of your machine.

Connect the welding torch (gas or liquid cooled) to the Euro plug of the intermediate drive.

For the connection of a gas-cooled welding torch, the water connections can be bridged in systems that are intended for water cooling. This creates a connection between port A water supply (blue) and port B water return (red). Application only when using a gas-cooled burner.

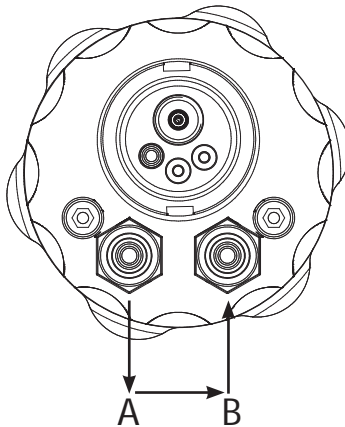

6.3. Introducing wire

Lay out the intermediate drive with stretched hose as straight as possible. Open the intermediate drive in order to observe the correct wire feeding process. Place the wire reel in the feeding device of your welding source. Deburr the cut welding wire with emery cloth or file. If the wire is deburred and reasonably straight, it will thread itself. In case of a fault, stop and insert the wire by hand into the wire guide.

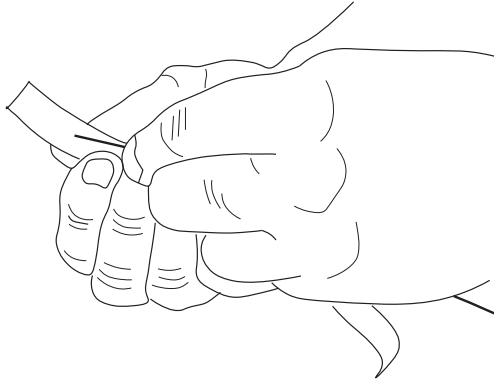

NOTE

Deburr the interface on the wire every time the wire is changed.

6.4. Opening/closing the pressure arm

The wire can be extended in idle mode. In special cases you can open/close the pressure arm (dark grey) manually. To do so, open the housing, unlock the bayonet and pull the slider back.

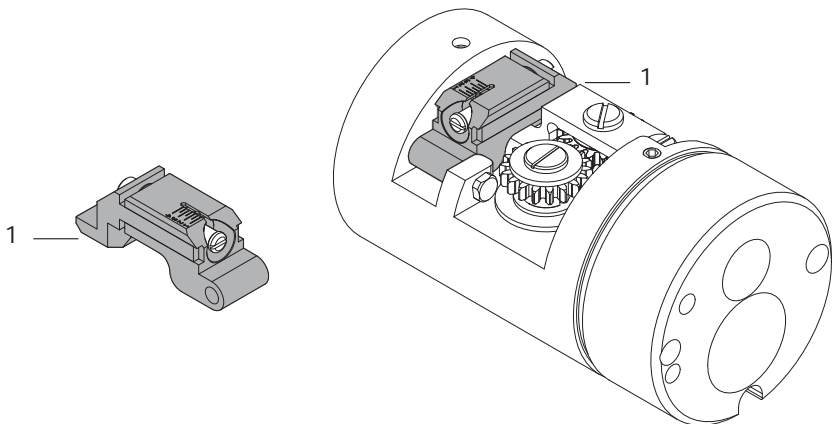

To open lift the pressure arm (dark grey) at position [1] with a slotted screwdriver.
To close, press the pressure arm down until it locks into place.

6.5. Changing the feed roller

Open the pressure arm. Open the fastening screw [1].

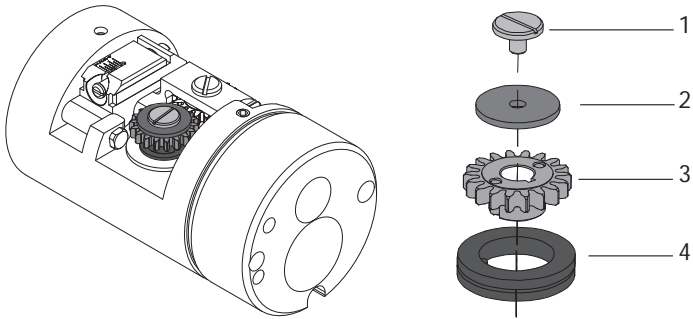

Remove the driving sprocket, then pull the feed roller [4] from the sprocket [3]. Then replace the feed roller and reassemble in reverse order.

6.6. Exchanging the wire guide

Open the Allen screw [1]. Replace the wire guide [2]. For exact positioning, make sure that the notch [3] is positioned under the Allen screw. Then carefully tighten the Allen screw again.

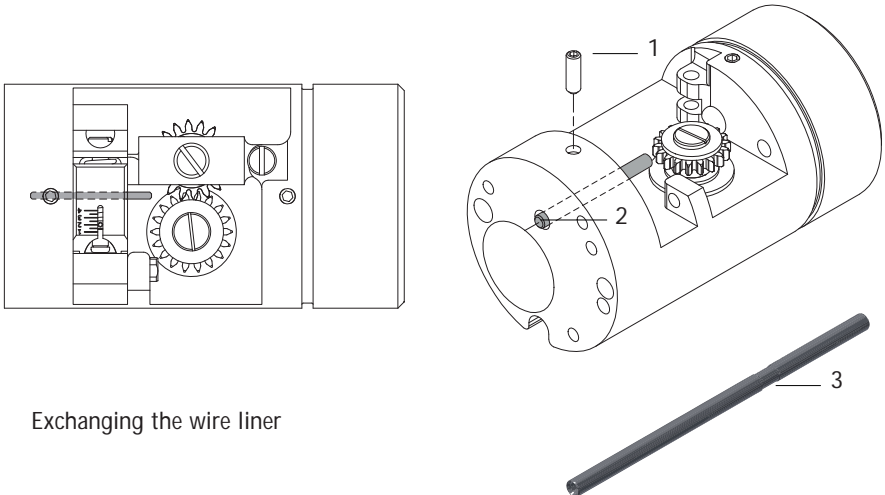

6.7. Exchanging the wire liner



Plastic wire guides with wire spiral attachment, can be used for aluminium, copper, nickel and stainless steel wires. Lay the hose pack out straight. Then loosen the union nut (grey) with a size 12 open-end wrench and remove it.

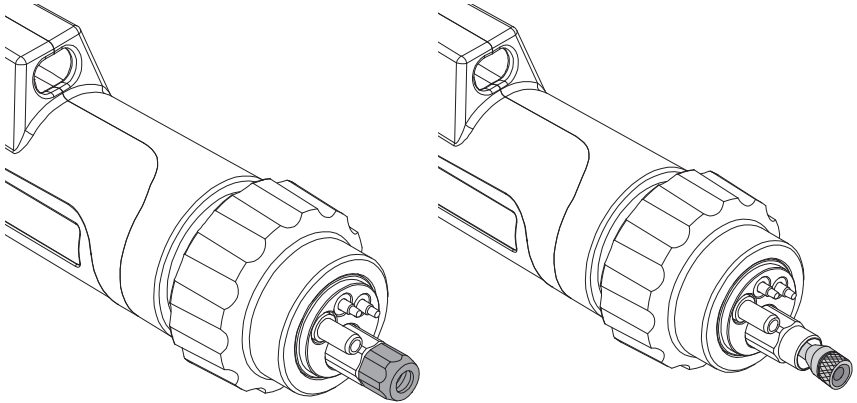

After removing the union nut the nipple of the wire guide spiral becomes visible. Use the same to pull the wire guide spiral out of the hose pack.

There are wire guide spirals with firmly pressed nipples and wire guide spirals with clamping nipples. If the nipple is not already firmly pressed, push it onto the wire guide spiral. Then insert the new wire guide spiral into the hose pack and measure the length that protrudes from the central adapter to the O-ring on the nipple.

Pull out the wire guide spiral again and cut off the measured length -1 cm, the cut edge must be deburred.

Push the wire guide spiral back in and tighten the union nut again hand-tight with the open-end wrench.

NOTE

 Always check that the wire guide is fastened correctly.

6.8. Coolant (this is only required for liquid-cooled welding torches.)



WARNING



Risk of burns

Liquid-cooled torches will overheat if the coolant level is too low. Check the coolant level in the cooling unit on a regular basis.



NOTE

The cooling system and welding torch must be thoroughly rinsed and filled every time initial installation is carried out, or whenever the hose pack is changed.



CAUTION

Material damage may occur

Damage to feed device and torch due to defective coolant connection. Be mindful of the flow and return coolant connections on the cooling unit.

Coolant flow	blue
Coolant return	red

- Connect the hose on the welding torch from the blue coolant flow to blue quick-coupling NW5 on the welding power source's cooling unit.
- Connect the hose on the welding torch from the red coolant return to the red quick-coupling on the welding power source's cooling unit.

The coolant system is connected.

- Now rinse the welding torch with coolant, top up coolant if required.
- To do this, run the welding machine's own coolant flow program 2 to 4 times.
- The longer the welding torch is, the longer the coolant rinsing program must be used.

6.9. Setting the shielding gas quantity



NOTE

The type and quantity of the shielding gas to be used always depends on the welding task.



NOTE

To prevent a blockage due to impurities in the inert gas supply, briefly open the cylinder valve before connection and thus flush out any impurities. This ensures a safe gas flow afterwards. All inert gas connections must be gas-tight!

6.10. Application

Connect the shielding gas cylinder to the welding power source or the feed unit, then adjust the gas flow quantity to the shielding gas cylinder's pressure reducer.



NOTE

Check

- before connecting to the feed unit that the correct wire guide (guide spiral or plastic core) has been installed for the appropriate wire type in the welding torch's hose pack.
- that the equipment parts have been fitted on the torch elbow for appropriate wire diameters.
- that cooling unit functionality is ensured with liquid-cooled welding torch designs.

7. The control unit

7.1. Overview

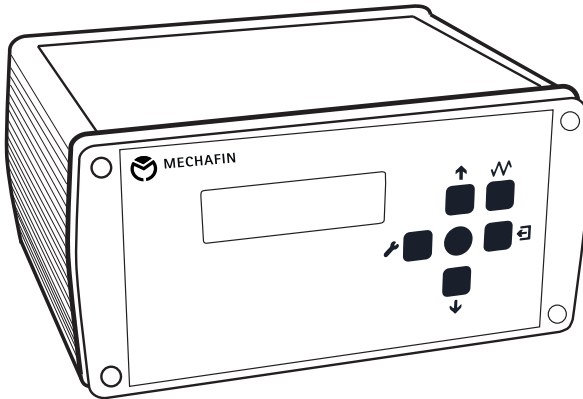

Front view

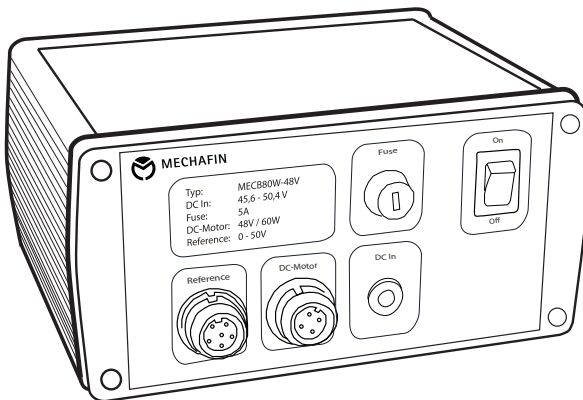

Rear view

7.2. Technical data

Protection type:	IP67 (except debug BNC connectors)
Power supply:	100 .. 240 VAC, max. 2.0 A, 50/60 Hz
Fuse protection:	2.5 AT, 5 x 20 mm
Internal supply:	48 VDC, max. 1.6 A (75 W)
Reference input:	0 .. ± 50 V, max. 5 mA
Motor output:	± 3.6 V .. ± 48 V, max. 3 A, software limited to 60 W
Max. motor acceleration:	30 m/min/s
Push-pull speed:	± 1 m/min .. ± 30 m/min

7.3. Pin assignment

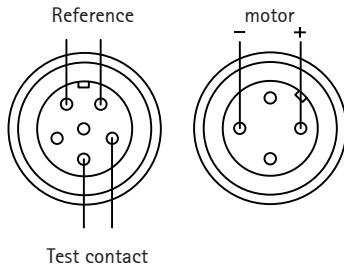







The test contact of the reference connector is used for connection detection of the reference cable. The two pins must be connected directly in the connector. The reference cable is connected to the power supply (+/-) at the master motor of the feed unit in the welding power source with connection to the supplied cable clamps.

7.4. Operating the control unit

The push-pull device is entirely operated with six push buttons. There are five different program modes: Standby, Run, Parameter, Setup and Error. The button functions depend on the current program mode.

The table below provides an overview:

Button	Program mode			Button > 2s press
	Run / Standby	Parameter / Setup	Error	
	Change to „Parameter“ status	no function	Change to „Parameter“ status	no function
	no function	Back to „Run“	no function	no function
	no function	Increase parameter value	no function	Increase parameter value quickly
	no function	Reduce parameter value	no function	Quickly reduce parameter value
	Switch on push-pull (Jog function)	no function	Switch on push-pull (Jog function)	Switch on push-pull (Jog function)
	no function	Confirm set parameter, jump to next parameter	no function	no function

7.5. Operation overview

Operation in regular mode

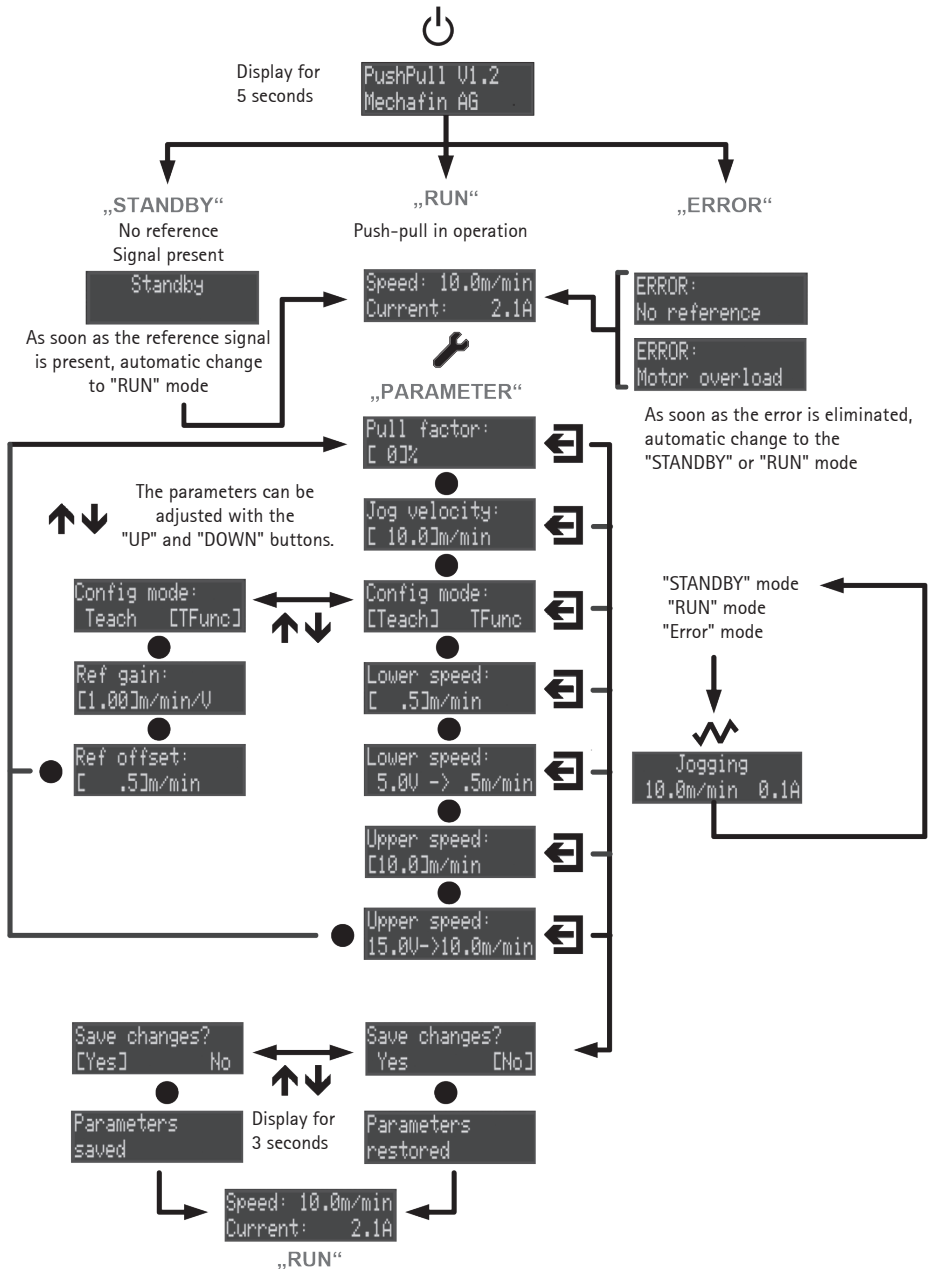

Operation in setup mode

By pressing the button  during the welding process, you enter "SETUP MODE" for advanced settings.

The cable length is adjust here.

The cable length is calculated on the basis of the following formula:

$$\text{Length (m)} \times 0.08 + 3.4$$

5 m = value 3.8
 10 m = value 4.2
 15 m = value 4.6
 20 m = value 5.0
 25 m = value 5.4

The value in the scheme on the right corresponds to a length of 20 m

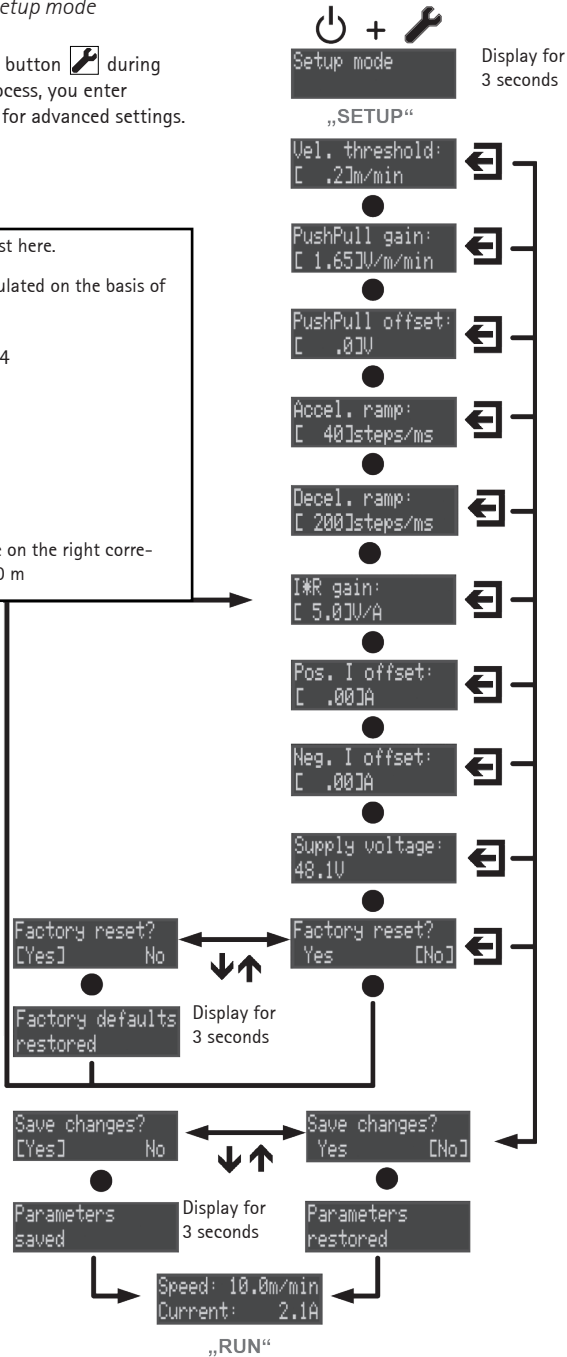

7.6. Program modes

Standby mode

```
Standby
```

If the reference cable is connected, but no reference signal is present at the input, the control unit is in standby mode. In this state the motor on the push-pull unit is switched on and off. As soon as a voltage is measured at the "Reference" input, the unit automatically switches to run mode and the push-pull unit runs at the preset speed.

Run mode

```
Speed: 10.0m/min
Current: 2.1A
```

In run mode, the push-pull unit operates at the speed specified at the "Reference" input. The current speed and motor current are shown on the display.

Parameter mode

```
Pull factor:
[ 0 ]%
```

Pull factor: This value is used to set the percentage by which the push-pull unit should run faster than the specified reference speed of the welding machine. Value range: [0..30] %

Jog velocity

```
Jog velocity:
[ 10.0 ]m/min
```

Jog velocity: Push-pull velocity in jog mode. By pressing the Jog button  the program leaves the Run mode and the push-pull unit runs with the speed set in this parameter. By entering negative values, the push-pull unit can also be operated in the opposite direction. Value range: \pm [0..30] m/min

Teach config mode

```
Config mode:
[Teach] TFunc
```

In [Teach] config mode, a straight line equation for the speed control of the push-pull unit is calculated on the basis of two defined speeds, depending on the specified voltage at the reference input. For this purpose, the current speed of the push-pull unit must be configured for two given reference voltages, „Lower U_{REF}“ and „Upper U_{REF}“. These recorded values must be entered in the corresponding parameters „Lower speed“ and „Upper speed“.

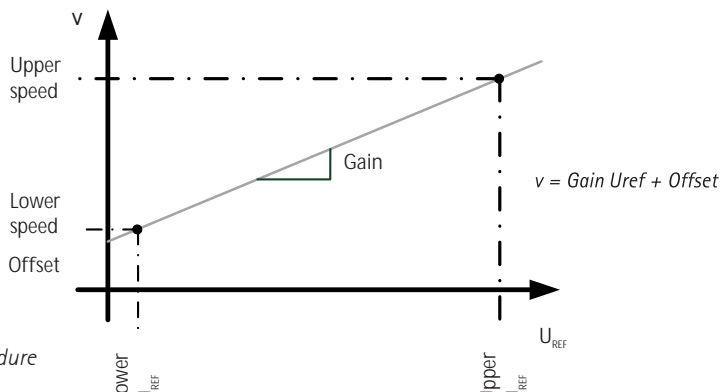

[Teach] procedure

```
Config mode:
[Teach] TFunc
```



```
Lower speed:
[ .5]m/min
```



```
Lower speed:
5.0V -> .5m/min
```



```
Upper speed:
[10.0]m/min
```



```
Upper speed:
15.0V->10.0m/min
```

1.) Select [Teach] config mode

2.) Lower speed: Lower speed reference value.
Value range: [0.1..30] m/min

As a check, the measured reference voltage is displayed at the current speed „Lower speed“.

3.) Upper speed: Upper speed reference value.
Value range: [0.1..30] m/min

For control purposes, the measured reference voltage is displayed at the current speed „UPPER speed“.

When saving the parameters, the two straight line points are converted into gain and offset values and stored in the memory.

Possible error messages after setting the [Teach] parameters:

```
ERROR:
Lspeed > Uspeed
```

Ensure that the following conditions are fulfilled for the above mentioned parameters:

```
ERROR:
Lvolt >= Uvolt
```

Lower speed \leq Upper speed
Lower $U_{REF} <$ Upper U_{REF}

```
ERROR:
Gain overflow
```

If these conditions are not fulfilled when exiting the parameter settings, an error message is output (see images on the left).

```
ERROR:
Offset overflow
```

If the calculated gain or offset is too high, this is also indicated by a message. In all cases, after three seconds the system switches back to the „Lower speed“ parameter.

If the dependence of reference voltage and speed is known, it can be entered directly in „[TFunc] config mode“ using the two parameters Offset and Gain.

```
Config mode:
[Teach] TFunc
```



```
Lower speed:
[ .5]m/min
```



```
Lower speed:
5.0V -> .5m/min
```

1.) Select [Teach] config mode

2.) Ref gain: known gain of the line equation
Value range: [0.1..5.0] m/min/V

3.) Ref offset: known OFFSET of the line equation
Value range: \pm [0..30.0] m/min

Setup mode:

```
Setup mode
●
Vel. threshold:
[ .2]m/min
●
PushPull gain:
[ 1.65]V/m/min
●
PushPull offset:
[ .0]V
●
Accel. ramp:
[ 40]steps/ms
●
Decel. ramp:
[ 200]steps/ms
●
I*R gain:
[ 5.0]V/A
●
Pos. I offset:
[ .00]A
●
Neg. I offset:
[ .00]A
●
Supply voltage:
48.1V
●
Factory reset?
[Yes] No
```

Setup mode: In „Setup mode“ adjustments can be made to adjust the push-pull control to a specific push-pull unit. These parameters should normally only be changed by the manufacturer.

Vel. threshold: As long as the reference voltage or the target speed is below the set threshold value, the push-pull unit is inactive („Stand-by“).

PushPull gain: This parameter is used to adjust the gain of the transfer function between the push-pull control and the push-pull motor.

PushPull offset: With this parameter the offset of the transfer function between the push-pull control and the push-pull motor can be set.

Accel. ramp: This value determines the steepness of the acceleration ramp in PWM steps per millisecond (see below). Caution: Higher values lead to higher load on the electronic components.

Decel. ramp: Decel. ramp: This value determines the steepness of the deceleration ramp in PWM steps per millisecond (see below).

⚠ Caution: Higher values lead to higher load on the electronic components.

I*R gain: This parameter sets the gain of the I*R compensation.

Pos. I offset: Correction value of the current measurement for positive output voltages.

Neg. I offset: Correction value of the current measurement for negative output voltages.

Supply Voltage: This value is used to control the internal power supply.

Factory Reset: Default values are loaded for all parameters.

Note on the acceleration ramps:

The full range of the output voltage extends over 32,768 PWM steps. A speed change of 1 m/min corresponds approximately (depending on the load) to 1100 PWM steps. Thus a value of 40 steps/ms leads to an acceleration ramp of about 35.5 m/min/s. An acceleration of 0 to 10 m/min takes 282 ms.

Default values

A "Factory reset" loads the following parameter values:

Pull factor:	[10] %
Jog velocity:	[10] m/min
Ref gain:	[0.2] m/min/V
Ref offset:	[-0.3] m/min
Vel. Threshold:	[0.3] m/min
PushPull gain:	[1.65] V/m/min
PushPull offset:	[0.0] m/min
Accel. ramp:	[40] steps/ms
Decel. ramp:	[200] steps/ms
I*R gain:	[5] V/A
Pos. I offset:	[0] A
Neg. I offset:	[0] A

Error mode

```
ERROR:
No reference
```

No reference: The cable at the reference input is not connected. This is detected by a wire jumper in the cable connector. As soon as the cable is plugged in, the program returns to Run mode.

```
ERROR:
Motor overload
```

Motor overload: The motor was overloaded over a longer period of time. The motor is switched off.

⚠ Attention: After about 30 seconds the motor is switched on again and the program returns to Run mode.

```
ERROR:
Motor OTW
```

Motor OTW: Over temperature warning of the motor driver on the MMU 01 electronics. As soon as the temperature is back in the permitted range, the program returns to the „Run“ state.

```
ERROR:
Motor FAULT
```

Motor FAULT: Protection mechanism of the motor driver on the MMU 01 electronics has responded, the motor is switched off immediately. The error is cleared once the unit is switched into Standby mode

7.7. Commissioning the intermediate drive with the control unit

The Mechafin control unit enables the Mechafin intermediate drives to be installed on most MIG/MAG welding machines. Before the first welding attempt, the machine, the control unit and the intermediate drive must be adjusted to each other. (teach) For this purpose the components are connected as follows.

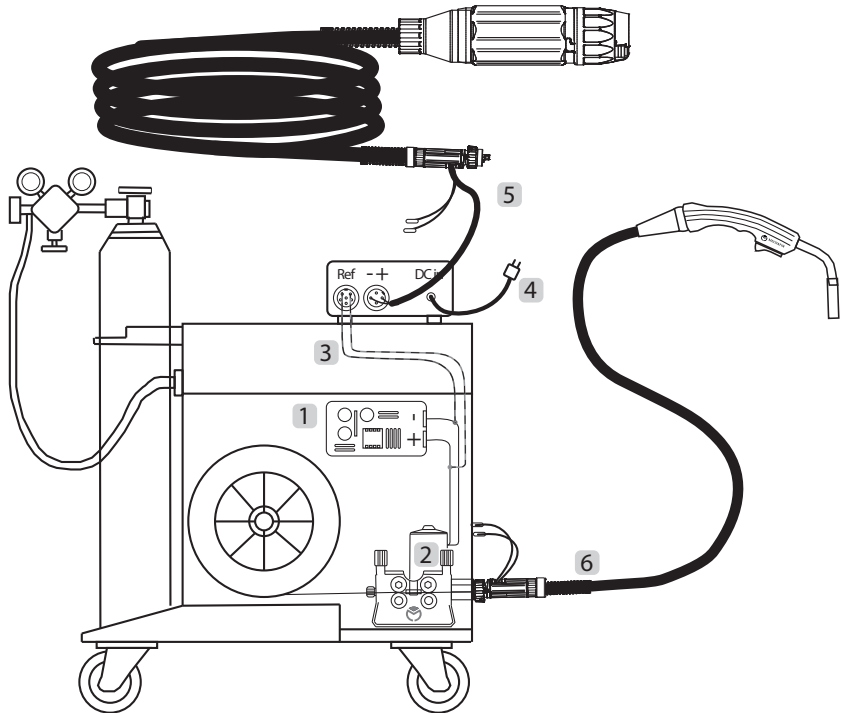

1. Disconnect the cable that goes from the control board [1] to the motor of the wire feed unit [2].
2. Now connect the "Reference - Cable" [3] (6-pin plug) with the help of the cable clamps with (+/-) of the master motor.
3. Connect the power cable [4] of the control unit to a plug with your country standard.
4. Connect the power cable [5] of the intermediate drive to the control unit.
5. Connect a welding torch [6] to the welding system to start the welding process and the calibration process with the push button.
6. Start the calibration process.



7.8. Calibration process of the control unit during commissioning

Press the button with the wrench  once to start the process

Press Confirm twice  to enter the "Config mode"

Press the up arrow key  once to go to "Teach"



Press Confirm once 

The display now shows "Lower speed"; set the lowest value of your welding current source (welding system) with the up arrow key  or the down arrow key . For example 5 m/min.

To save the value, press once to confirm 

Now start the welding process at the lowest speed indicated above your welding current source. Weld for approx. 20–30 seconds in one go. During the welding process, confirm the speed by pressing the Enter key once  until the values on the system and the box run synchronously.



 It is imperative that this happens during the welding process!

The display now shows "Upper speed"; set the uppermost value of your welding current source (welding system) with the up arrow key  or the down arrow key . For example 25 m/min.

To save the value, press once to confirm 

Now start the welding process at the highest speed indicated above, from your welding current source. Weld for approx. 20–30 seconds in one go. (You can also simply hold the trigger of your welding gun pressed down.) During the welding process, confirm the speed by pressing the enter button once 

 It is imperative that this happens during the welding process!

Exit the "Teach" menu with the Exit button , the display will show "Save Changes"; select "Yes" with the up arrow button  or the down arrow button .

To save the value, press once to confirm 

The display now shows "Parameters saved"

 The intermediate drive and the welding machine should now run synchronously!

7.9. Fastening the control unit

 The control unit must be firmly attached to the welding machine so that it cannot fall down; there are two options.

- 1.) The control unit can be fastened by means of the enclosed mounting feet.
- 2.) The control unit can be fastened by means of the enclosed Velcro adhesive tapes.

 Now connect the welding system, intermediate drive and welding gun according to the following diagram.

7.10. Connecting the intermediate drive for welding

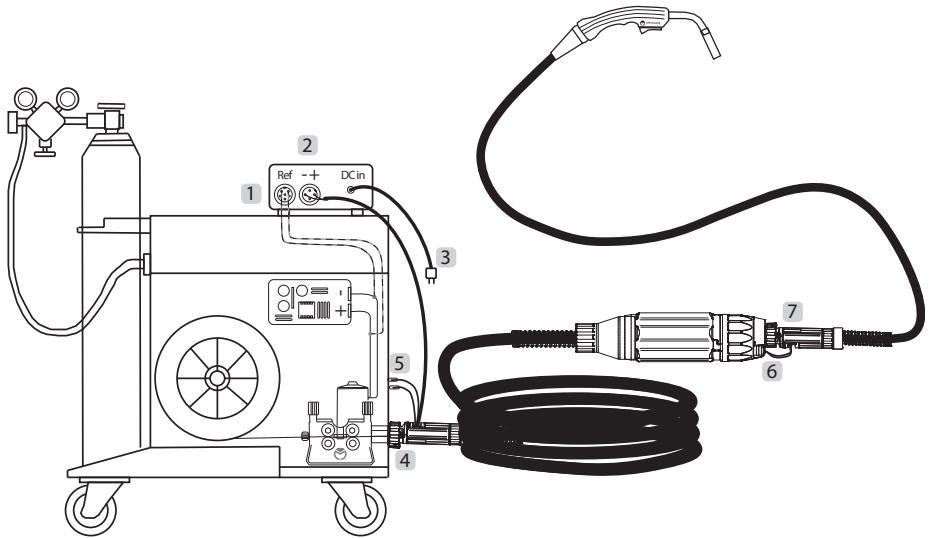

1. Connect the "Reference - Cable" [1] (6-pin plug) to the control unit.
2. Now connect (4-pin plug) the hose package [2] to the control unit.
3. Connect the power cable [3] of the control unit to a plug with your country standard.
4. Connect the Euro plug [4] of the hose package to the welding current source (welding system to
5. If your welding torch has liquid cooling, close the two connections [5] (blue/red) to the corresponding connections of your system.
6. If your welding torch has a liquid cooling system, connect the two connectors [6] (blue/red) to the corresponding connections on your intermediate drive.
7. Connect the Euro plug of the welding torch [7] to the intermediate drive.

7.11. Starting the welding process

CAUTION

Danger from inhalation of gas vapours!
All metal vapours are toxic and pathogenic.



For the entire duration of the work:

- Always ensure adequate ventilation or extraction!
- Use respiratory protection equipment, if required!
- Adhere to the applicable MAC values (max. allowable workplace concentration)!
- The ISO standard values 21904 apply

DANGER

Glare

The light arc is very intense and dangerous to skin and eyes.

- Always use suitable hard hats and protective clothing!
- The ISO11611 and ISO11611 standards provide a good source of orientation



NOTE

The gas quantity always depends on the respective welding task. The gas quantity must always be adjusted for the equipment and the gas sparger.

8. Operation

IMPORTANT

- Open the gas valve on the shielding gas cylinder.
- Switch on the power source.
- Set gas quantity.
- Set welding parameters.

 The welding process is prepared.

CAUTION – Material damage

All hose packs that have been fitted with PVC hoses may spring a leak if the return temperature is exceeded in the crushing zone. In this case, it must be ensured that the return temperature of 60°C is not exceeded. It must be ensured that the cooling unit is delayed by e.g. 5 min. for liquid-cooled hose packs after welding has been completed as per the power source manufacturer's specifications so the welding torch can be cooled down correctly.

IMPORTANT

- Always wait for the shielding gas flow time to protect the welding seam.
- After the cooling unit fan has switched off, the power source can be turned off.
- Now close the shielding gas cylinder shut-off valve to prevent gas loss.

 The welding process is completed.

9. Maintenance | Cleaning

9.1. General information

 **DANGER**
Risk of injury

In case of an unexpected start of maintenance, installation and repair work, the following applies for the entire duration of the work:

- always pull out the mains plug.
- always shut off the gas supply.
- always switch off the power source.



 **DANGER**
Dangerous voltage

Defective or damaged cables may lead to an electric shock.

For the entire duration of the work:

- All live cables and connections must be checked that they have been installed correctly, or whether they are damaged.

 **WARNING**
Risk of crushing



Hands may be pulled in or crushed due to running gears or feed rollers.

- Never reach into running gears and feed rollers!

9.2. Hose pack

 **WARNING**
Risk of burns



- The torch will quickly overheat if the coolant level is too low.
- Check the coolant level in the cooling unit at regular interval!

 **IMPORTANT** – MECHAFIN AG offers factory repairs if a repair is required.

- Always check the union nut of the hose pack to the power source for a tight fit.
- Check wire liners or plastic wire guides for wear and tear or contamination and replace them if necessary by MECHAFIN AG original wire liners or plastic wire guides.
- Replace damaged or worn parts exclusively with original MECHAFIN AG spare parts.

9.3. Wire liner

 **NOTE**
Observe the specifications listed in Section 6.7 "Mounting the wire liner".

NOTE

If this does not lead to the desired success, contact your specialised dealer or get in touch with the manufacturer. Please also observe the manufacturer's instructions i.e. on the power source, welding torch and cooling unit.

10. Disassembly and disposal

Materials

These products mostly consist of metal materials, which can be melted down again. They can be re-used an almost unlimited number of times as a result.

Packaging

MECHAFIN AG has reduced the transport packaging to the essentials. Attention is paid to potential recycling when selecting packaging materials.

11. Emergency

Interrupt the power supply immediately in case of emergency. For additional measures, please refer to the power source manufacturer's operating manual.

12. Warranty

These intermediate drives are products of MECHAFIN AG. MECHAFIN AG guarantees flawless manufacture and accepts a production and functional warranty ex-factory as per the state of the art and applicable regulations. Warranties can only be given for production faults, but not for damage that can be attributed to natural wear or improper handling.

MECHAFIN AG has the right to make changes to the operating manual without prior notice, which may be necessitated due to printing errors or potential neglect of the information contained therein, or further product development. Any changes will then be listed in newer editions.

13. Faults and how to remedy them

Fault	Cause	Remedy
➤ Welding torch becomes too hot	<ul style="list-style-type: none"> ➤ Contact tip / gas sparger has not been tightened firmly ➤ Power connections on welding torch and work piece are loose ➤ Coolant flow is too low 	<ul style="list-style-type: none"> ➤ Inspect and tighten, if required ➤ Inspect and tighten, if required ➤ Inspect cooling system
➤ No button function	<ul style="list-style-type: none"> ➤ Contact cable defective ➤ Flow sensor in cooling unit has switched itself on 	<ul style="list-style-type: none"> ➤ Inspect and repair, if required ➤ Check coolant fluid and top up, if required
➤ Wire on contact tip solidified	<ul style="list-style-type: none"> ➤ Parameter settings are incorrect ➤ Contact tip is worn ➤ Wire backfire parameters set too short 	<ul style="list-style-type: none"> ➤ Inspect parameters and correct, if required ➤ Replace contact tip ➤ Inspect parameters and correct, if required
➤ Irregular wire feed	<ul style="list-style-type: none"> ➤ Wire liner defective or blocked ➤ Wire Ø and contact tip do not fit ➤ Contact pressure on feed unit set incorrectly 	<ul style="list-style-type: none"> ➤ Blow air through on both sides and replace, if required ➤ Replace contact tip or wire ➤ Adjust according to manufacturer specifications
➤ Light arc between gas nozzle and workpiece	<ul style="list-style-type: none"> ➤ Contact tip and gas nozzle have a tip bridge to one another 	<ul style="list-style-type: none"> ➤ Clean the inside of the gas nozzle and spray spatter protection or replace gas nozzle
➤ Turbulent light arc	<ul style="list-style-type: none"> ➤ Contact tip does not fit wire Ø or contact tip is worn ➤ Welding parameters set incorrectly ➤ Worn wire guide 	<ul style="list-style-type: none"> ➤ Inspect contact tip and replace, if required ➤ Inspect parameters and correct, if required ➤ Replace wire guide
➤ Porosity formation	<ul style="list-style-type: none"> ➤ Gas nozzle blocked due to welding spatter that is too intense, gas coverage is too little or existent as a result 	<ul style="list-style-type: none"> ➤ Clean the inside of the gas nozzle and spray spatter protection or replace gas nozzle ➤ Check gas bottle, pressure settings ➤ Shield welded joint with protective walls before the atmospheric air



14. Accessories and wear parts

Control units

Item number	Cooling	Connection	for welding wire	Wire Ø [mm]	Length [mm]
119864	Liquid	Euro	Steel	1.2	5.0
117218	Liquid	Euro	Steel	1.2	10.0
117219	Liquid	Euro	Steel	1.2	15.0
117217	Liquid	Euro	Steel	1.2	20.0
117220	Liquid	Euro	Steel	1.2	25.0
119915	Liquid	Euro	Aluminium	1.2	5.0
117215	Liquid	Euro	Aluminium	1.2	10.0
117216	Liquid	Euro	Aluminium	1.2	15.0
118458	Gas	Euro	Steel	1.2	5.0
117208	Gas	Euro	Steel	1.2	10.0
117209	Gas	Euro	Steel	1.2	15.0
117210	Gas	Euro	Steel	1.2	20.0
117211	Gas	Euro	Steel	1.2	25.0
119916	Gas	Euro	Aluminium	1.2	5.0
117204	Gas	Euro	Aluminium	1.2	10.0
117205	Gas	Euro	Aluminium	1.2	15.0

Control units

Item number	Network supply [VDC]	Operating voltage [VDC]	Dimensions LxWxH [mm]	Net weight [kg]
119572	24	48	140 x 170 x 85	2.0
119769	48	48	140 x 170 x 85	2.0
118138	220	48	140 x 170 x 85	2.0

Wire guide tubes

Item number	Wire type	Wire diameter [mm]	Length [mm]	Net weight [kg]
114301	Steel	1.2	109.5	0.015
114302	Steel	1.5	109.5	0.015
114303	Steel	2.0	109.5	0.015
114304	Steel	2.5	109.5	0.015
116049	Aluminium	1.5	109.5	0.007
116050	Aluminium	2.0	109.5	0.007
116051	Aluminium	2.5	109.5	0.007



Feed rollers

Wire type	Wire Ø 0.8mm	Wire Ø 1.0mm	Wire Ø 1.2mm	Wire Ø 1.4mm	Wire Ø 1.6mm
Steel	114260	114261	114262	114265	114263
Flux-cored wire	-	119524	117494	117504	117498
Aluminium	114245	114246	114247	114250	114248

Wire liners

Length [m]	Steel / flux-cored wire 0.8 - 1.0mm	Steel / flux-cored wire 1.0 - 2.0mm	Aluminium wire 0.8 - 1.0mm	Aluminium wire 1.0 - 2.0mm
5.0	119918	119919	119920	119921
10.0	116413	116423	116476	116480
15.0	116079	116081	116477	116481
20.0	116414	116424	116478	116482
25.0	116080	116082	116479	116483

15. Length recommendation for the PUSH PULL

Maximum length recommendation for the PUSH PULL in relation to materials and gases

Materials	Gas	PushPull 5m	PushPull 10m	PushPull 15m	PushPull 20m	PushPull 25m
Aluminium, copper, nickel and other alloys	Argon 4.6					
	Argon 4.8 Argon: 80% + Helium: 20%	+++ + 3m torch	+++ + 3m torch	+-- only in exceptional cases + 3m torch	---	---
Pipe steel, structural steel, boiler plate, shipbuilding plate, fine-grained structural steel Case hardening + tempering steel	Argon: 82%					
	CO2: 18%	+++	+++	+++	+++	+++
CrNi steel, Cr steel and other alloy steels, Ni base alloys, duplex and superduplex steels	Argon: 97,5%					
	CO2: 2,5%	+++	+++	+-- only in exceptional cases + 4m torch	---	---



Mechafin AG
Chrümmacherstr. 3 | CH-8954 Geroldswil | Switzerland
Telephone +41 44 749 30 60 | Facsimile +41 44 749 30 70
Mail info@mechafin.ch | Web www.mechafin.com

Mechafin Ltd
Leigh Street | High Wycombe | Buckinghamshire | HP11 2QU UK
Telephone +44 1494 441 110 | Facsimile +44 1494 473 049
Mail enquiries@mechafin.co.uk | Web www.mechafin.com