

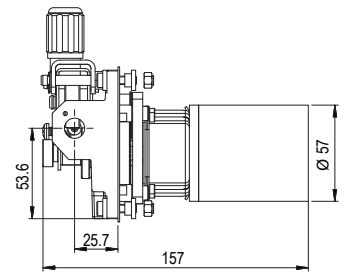

SERIES MEFR1042-BELT DRIVE WIRE DRIVE SYSTEM

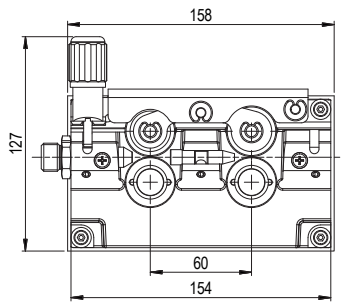
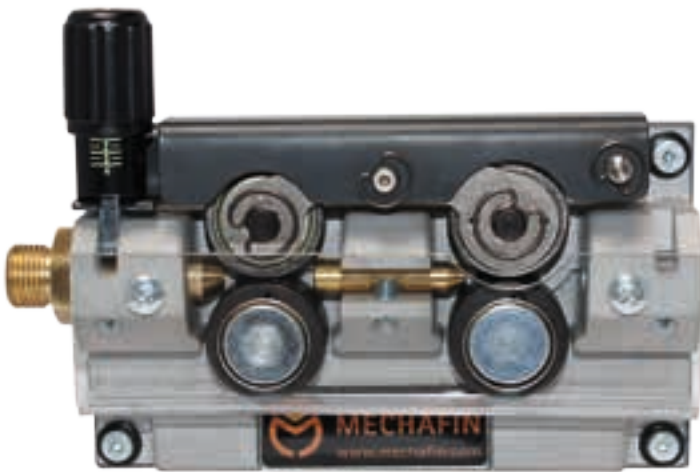

Technical Data:

Drive Mechanism:	gearbox / gear belt
Pressure Arm:	Steel / flat upper roll
Feed Plate:	Aluminium
Rolls:	30mm
Encoder	Item no.
100 pulse	116594
300 pulse	115647

Type	Drive Mechanism	Pressure Arm	Feed Roll	Item no.
MEFR1042-30-1012-Belt Drive	Belt Drive D5765	Pressure arm steel without encoder for aluminium	standard	116357
MEFR1042-30-1012-Belt Drive	Belt Drive D5765	Pressure arm without encoder	standard	117328
MEFR1042-30-1012-Belt Drive	Belt Drive	Pressure arm without encoder	standard	117469*
MEFR1042-30-1012-Belt Drive	Belt Drive LP58/360	Pressure arm with encoder PWB 100 pulse	standard	117622
MEFR1042-30-1012-Belt Drive	Belt Drive LP58/360	Pressure arm without encoder for steel	standard	117925
MEFR1042-30-1012-Belt Drive	Belt Drive LP58/360	Pressure arm with encoder PWB 300 pulse	standard	117926

* without motor



Gear Motor brushless:

These motors need a control electronic

Type	Voltage [V]	No Load		Maximum Efficiency				Gear ratio	Item no.
		Speed [rpm]	Current [A]	Speed [rpm]	Current [A]	Torque [mNm]	Output [W]		
BL5765-24100	24	7049	0.81	6126	5.40	155.5	99.7	1:24	116353
LP58 / 360 *	24	5374	0.51	4367	4.40	192.47	88.02	1:15	117621

* with overload clutch
other motors on request

Feed Rolls 30mm:

(only 2 driving rolls)



Type	Groove	Wire Ø	Item no.
Feed Roll V Groove 0.6 + 0.8mm	V	0.6 + 0.8mm	74238
Feed Roll V Groove 0.8 + 1.0mm	V	0.8 + 1.0mm	74129
Feed Roll V Groove 1.0 + 1.2mm	V	1.0 + 1.2mm	74109
Feed Roll V Groove 1.2 + 1.6mm	V	1.2 + 1.6mm	74102
Feed Roll U Groove 0.8 + 0.9mm A	U	0.8 + 0.9mm	74919
Feed Roll U Groove 1.0 + 1.2mm A	U	1.0 + 1.2mm	74796
Feed Roll U Groove 1.2 + 1.6mm A	U	1.2 + 1.6mm	74797
Feed Roll U Groove 2.4 + 3.2mm A	U	2.4 + 3.2mm	74798
Feed Roll V Groove 1.0 + 1.2mm knurled	V knurled	1.0 + 1.2mm	74289
Feed Roll V Groove 1.0/1.2 + 1.4/1.6mm knurled	V knurled	1.0/1.2 + 1.4/1.6mm	74913
Feed Roll V Groove 1.4 + 1.6mm knurled	V knurled	1.4 + 1.6mm	74251
Feed Roll V Groove 1.4/1.6 + 2.0/2.4mm knurled	V knurled	1.4/1.6 + 2.0/2.4mm	71008

other feed rolls see catalogue feed rolls or on request

Mechafin AG

Chrummacherstr. 3 | CH-8954 Geroldswil | Switzerland
Telephone +41 44 749 30 60 | Facsimile +41 44 749 30 70
Mail info@mechafin.ch | Web www.mechafin.com

Mechafin Ltd

Leigh Street | High Wycombe | Buckinghamshire | HP11 2QU UK
Telephone +44 1494 441 110 | Facsimile +44 1494 473 049
Mail enquiries@mechafin.co.uk | Web www.mechafin.com