

Euro Central Adaptor torch side with two spring-loaded pins

Applies for water cooled MIG/MAG Torch

Item number:	57341
Product weight (kg):	0.19 kg
Packing unit:	1

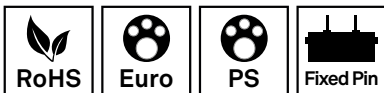
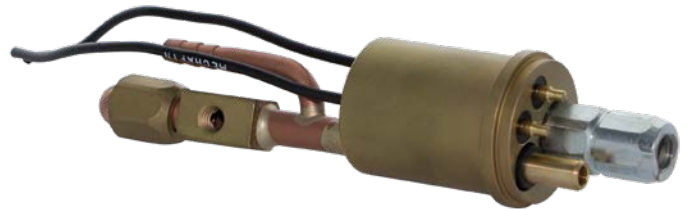

PRODUCT DESCRIPTION

Applies for water cooled MIG/MAG Torch

TECHNICAL CHARACTERISTICS

Version:	Round
Number of contact pins:	2
Pin type:	sprung
Cooling:	Water
Terminal side:	Welding torch
Hose package Connection:	Euro
Material:	Brass

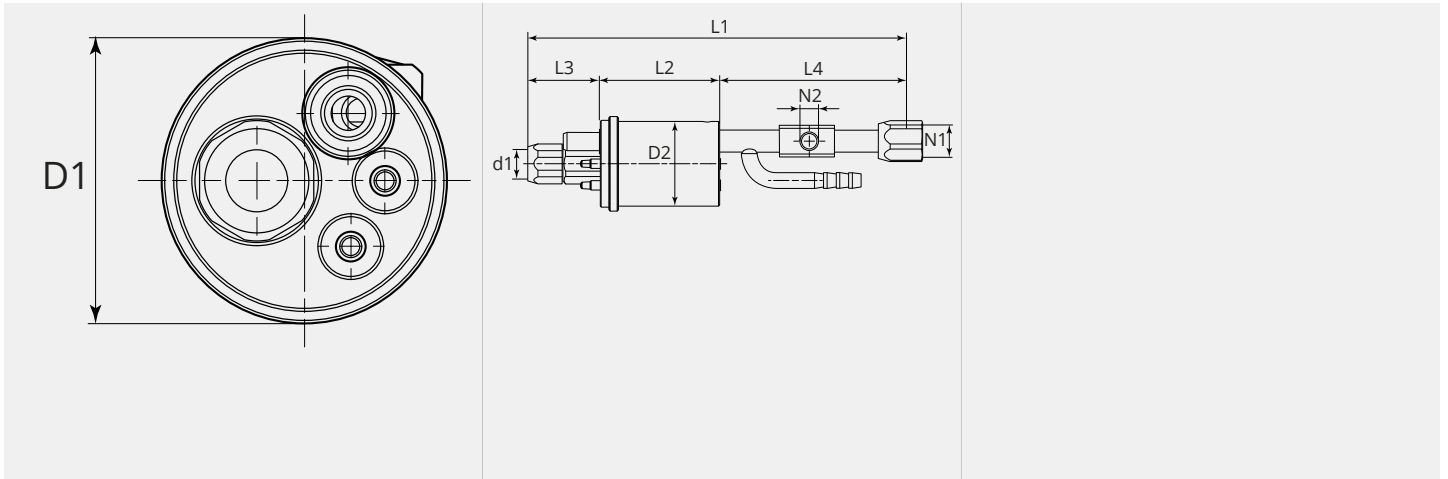
DIMENSIONAL DRAWING

DIMENSIONAL DRAWING

L1 (mm):	119.5
L2 (mm):	38.0
L3 (mm):	23.0
L4 (mm):	58.5
D1 (Ø):	30
D2 (Ø):	26.9
d1 (Ø):	6.5
N1:	M10x1
N2:	M6