

# Adapter support for water cooled MIG/MAG torches with 1 1/2-12UNF thread

Applies for euro central adaptor

Item number:	57088
Product weight (kg):	0.07 kg
Packing unit:	1



## PRODUCT DESCRIPTION

Applies for euro central adaptor

## TECHNICAL CHARACTERISTICS

Material:	Plastic
-----------	---------

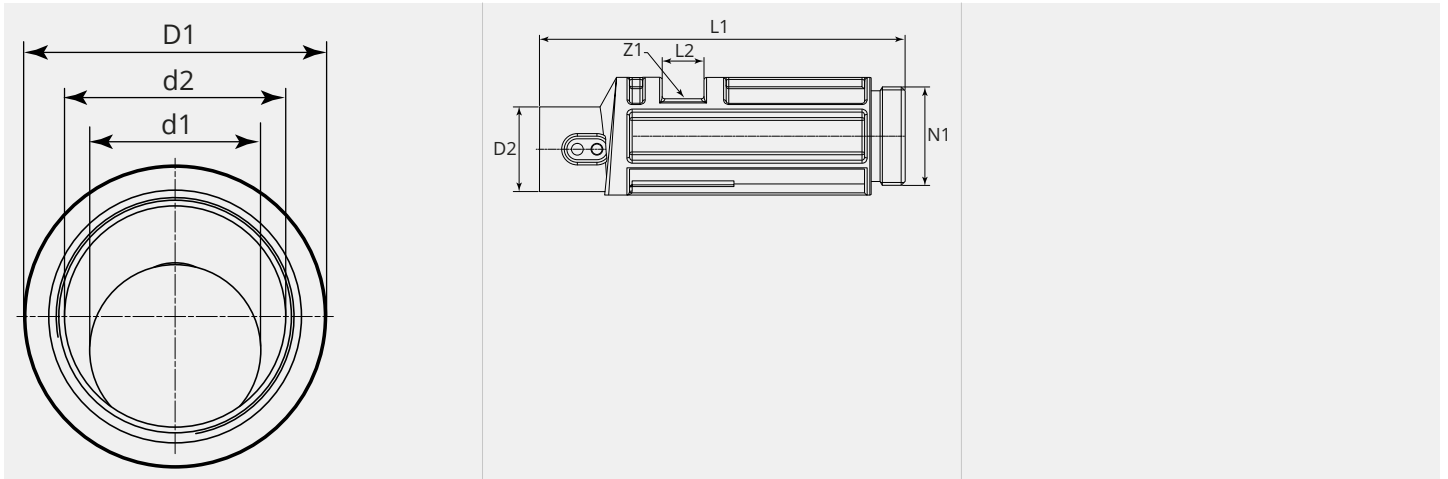
**DIMENSIONAL DRAWING**

**DIMENSIONAL DRAWING**

<b>L1 (mm):</b>	140.0
<b>L2 (mm):</b>	16.0
<b>D1 (Ø):</b>	45
<b>D2 (Ø):</b>	32.4
<b>d1 (Ø):</b>	25.5
<b>d2 (Ø):</b>	32.0
<b>N1:</b>	11/2"- 12UNF
<b>Z1:</b>	open