

# MIG/MAG Welding Gun Neck MER500ASC

Gas cooled for 500A, Swan Neck Angle 45°, for 0.8 - 2.4 wire

Item number: **55540**  
 Packing unit: **1**



## PRODUCT DESCRIPTION

Gas cooled for 500A, Swan Neck Angle 45°, for 0.8 - 2.4 wire

## TECHNICAL CHARACTERISTICS

Wire (mm):	0.8 - 2.4
Bending angle (°):	45
Max. current CO2 (A):	500
Duty Cycle CO2:	80
Max. current argon mixed gas (A):	340
Duty Cycle Argon mixed gas (%):	80
Cooling:	Gas
Suitable:	MER500ASC

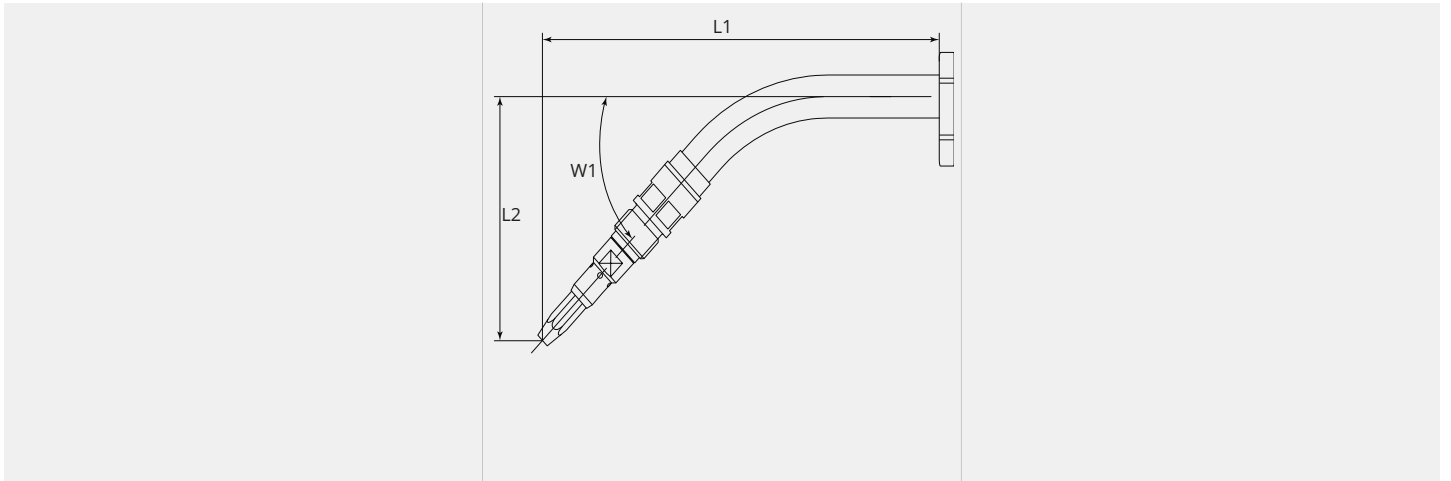
**DIMENSIONAL DRAWING****DIMENSIONAL DRAWING**

<b>L1 (mm):</b>	170.0
<b>L2 (mm):</b>	95.5
<b>W1 (°):</b>	45.0