

MIG/MAG Welding Gun Neck MER500ASC

Gas cooled for 500A, Swan Neck Angle 180°, for 0.8 - 2.4 wire

Item number: 55530

Packing unit: 1



PRODUCT DESCRIPTION

Gas cooled for 500A, Swan Neck Angle 180°, for 0.8 - 2.4 wire

TECHNICAL CHARACTERISTICS

Wire (mm):	0.8 - 2.4
Bending angle (°):	180
Max. current CO2 (A):	500
Duty Cycle CO2:	80
Max. current argon mixed gas (A):	340
Duty Cycle Argon mixed gas (%):	80
Cooling:	Gas
Suitable:	MER500ASC

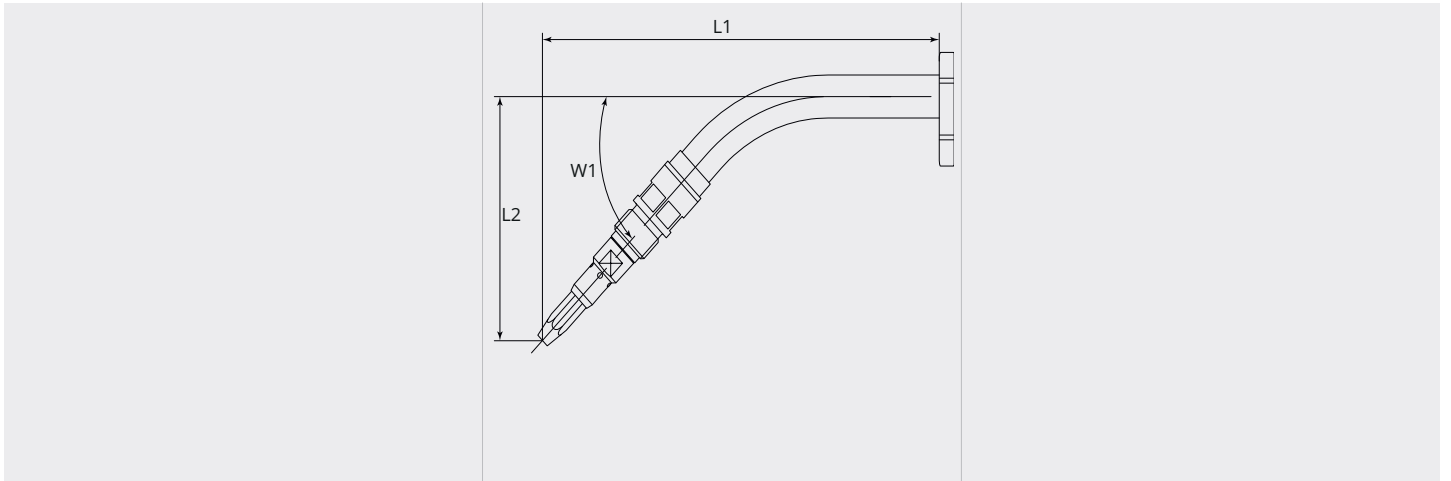
DIMENSIONAL DRAWING**DIMENSIONAL DRAWING**

L1 (mm):	206.0
W1 (°):	180.0