

MIG/MAG Welding Gun Neck MER400ASC

Gas cooled for 400A, Swan Neck Angle 45°, for 0.8 - 2.0 wire

Item number: 54540

Packing unit: 1



PRODUCT DESCRIPTION

Gas cooled for 400A, Swan Neck Angle 45°, for 0.8 - 2.0 wire

TECHNICAL CHARACTERISTICS

Wire (mm):	0.8 - 2.0
Bending angle (°):	45
Max. current CO2 (A):	400
Duty Cycle CO2:	80
Max. current argon mixed gas (A):	260
Duty Cycle Argon mixed gas (%):	80
Cooling:	Gas
Suitable:	MER400ASC

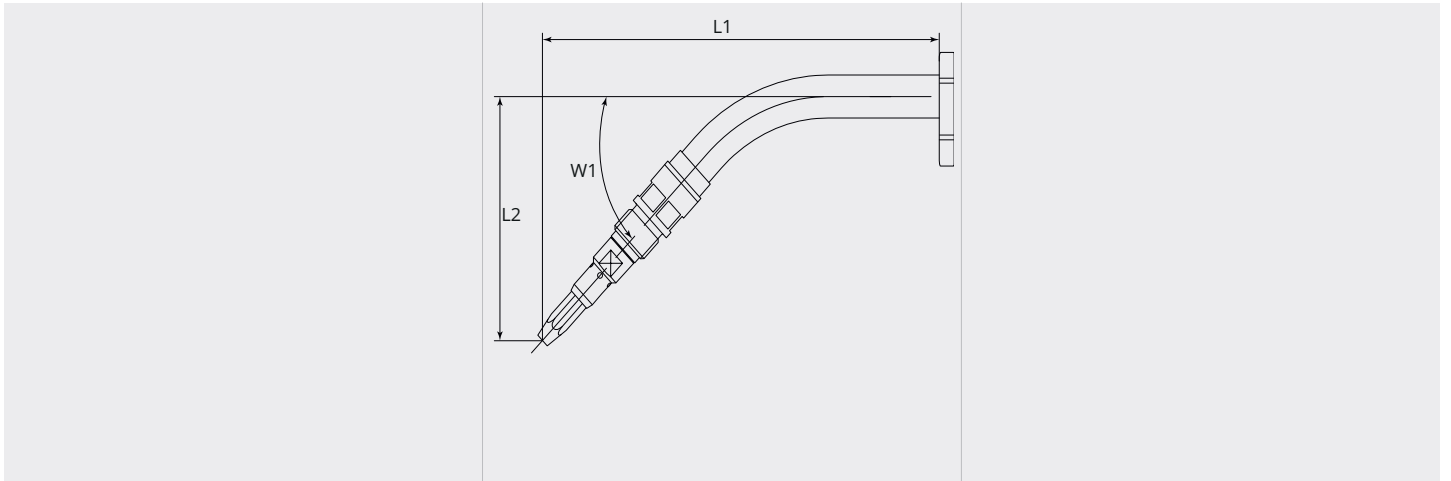
DIMENSIONAL DRAWING**DIMENSIONAL DRAWING**

L1 (mm):	169.5
L2 (mm):	95.5
W1 (°):	45.0