

MIG/MAG Welding Gun Neck MER300ASC

Gas cooled for 300A, Swan Neck Angle 45°, for 0.8 - 1.4 wire

Item number: 53540

Packing unit: 1



PRODUCT DESCRIPTION

Gas cooled for 300A, Swan Neck Angle 45°, for 0.8 - 1.4 wire

TECHNICAL CHARACTERISTICS

Wire (mm):	0.8 - 1.4
Bending angle (°):	45
Max. current CO2 (A):	300
Duty Cycle CO2:	80
Max. current argon mixed gas (A):	180
Duty Cycle Argon mixed gas (%):	80
Cooling:	Gas
Suitable:	MER300ASC

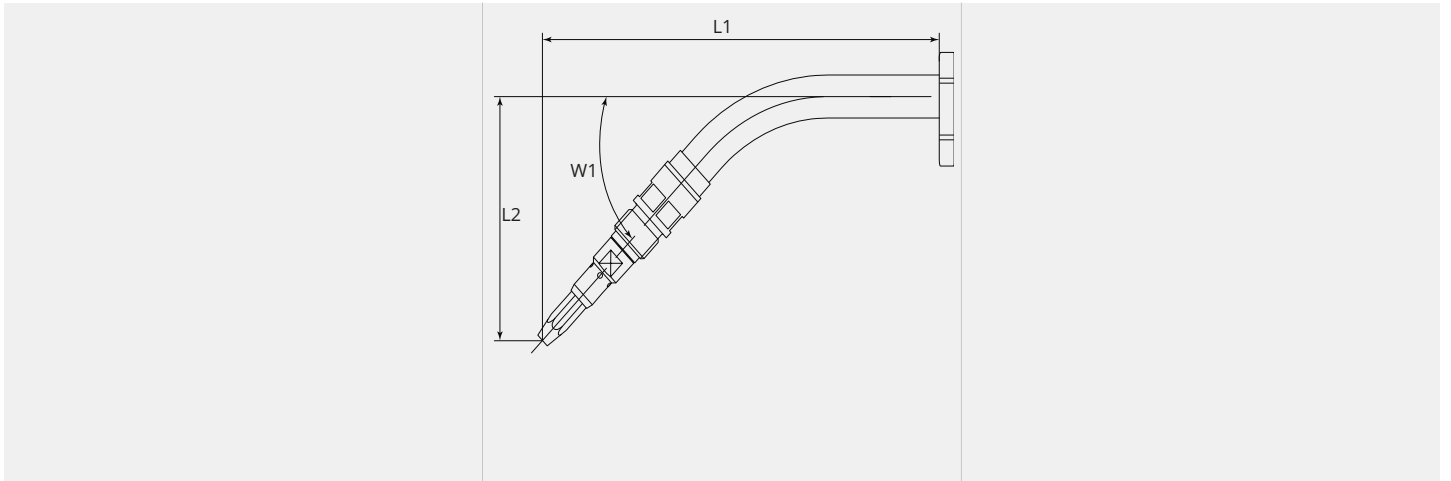
DIMENSIONAL DRAWING**DIMENSIONAL DRAWING**

L1 (mm):	171.0
L2 (mm):	96.5
W1 (°):	45.0