

# MIG/MAG Welding Gun Neck MER300ASC

Gas cooled for 300A, Swan Neck Angle 180°, for 0.8 - 1.4 wire

Item number:	53530
Product weight (kg):	0.3849 kg
Packing unit:	1



## PRODUCT DESCRIPTION

Gas cooled for 300A, Swan Neck Angle 180°, for 0.8 - 1.4 wire

## TECHNICAL CHARACTERISTICS

Wire (mm):	0.8 - 1.4
Bending angle (°):	180
Max. current CO2 (A):	300
Duty Cycle CO2:	80
Max. current argon mixed gas (A):	180
Duty Cycle Argon mixed gas (%):	80
Cooling:	Gas
Suitable:	MER300ASC

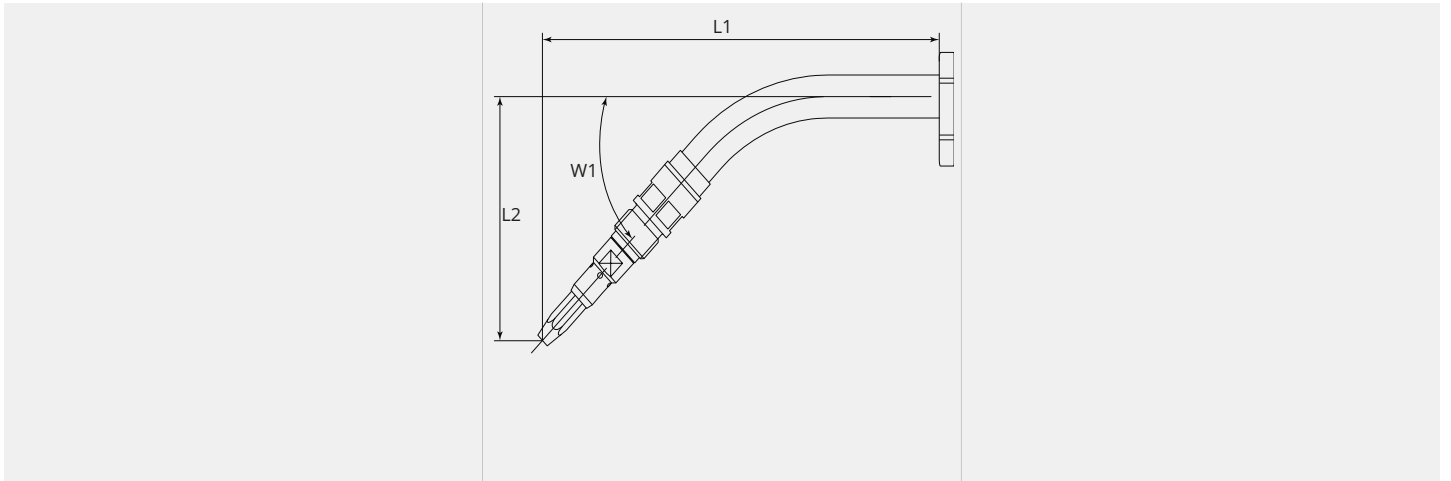
**DIMENSIONAL DRAWING****DIMENSIONAL DRAWING**

<b>L1 (mm):</b>	207.5
<b>W1 (°):</b>	180.0