

# MIG/MAG Welding Gun Neck MER352WSC

Water cooled for 350A, Swan Neck Angle 180°, for 0.8 - 2.0 wire

Item number:	53500
Product weight (kg):	0.386 kg
Packing unit:	1



## PRODUCT DESCRIPTION

Water cooled for 350A, Swan Neck Angle 180°, for 0.8 - 2.0 wire

## TECHNICAL CHARACTERISTICS

Wire (mm):	0.8 - 2.0
Bending angle (°):	180
Max. current CO2 (A):	350
Duty Cycle CO2:	100
Max. current argon mixed gas (A):	230
Duty Cycle Argon mixed gas (%):	100
Cooling:	Water
Suitable:	MER352WSC

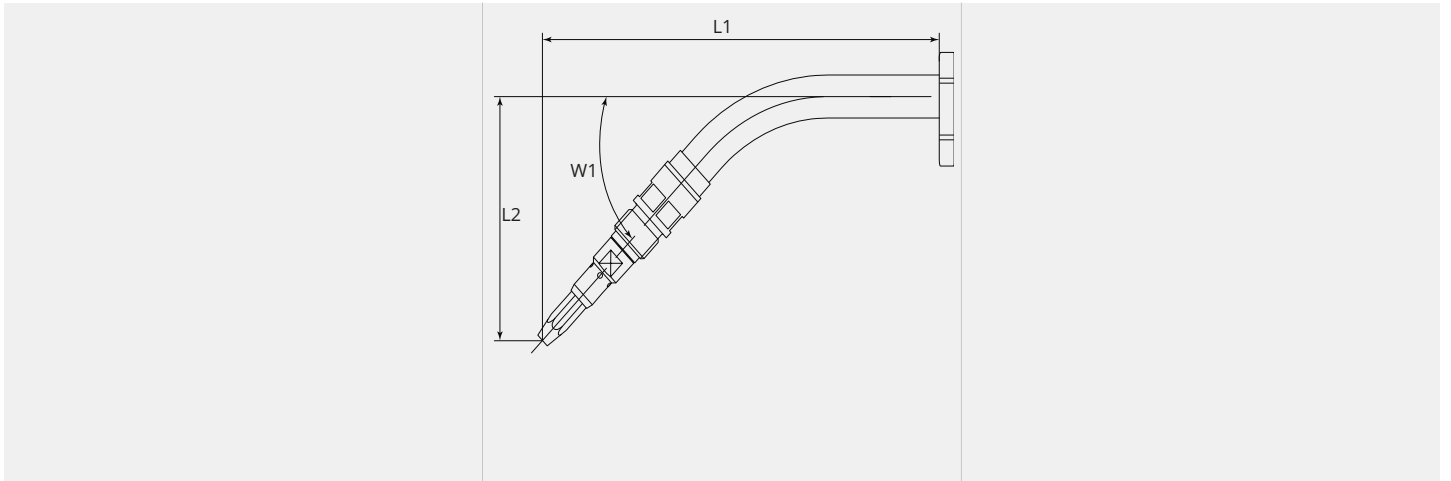
**DIMENSIONAL DRAWING****DIMENSIONAL DRAWING**

<b>L1 (mm):</b>	207.5
<b>W1 (°):</b>	180.0