

# MIG/MAG Welding Gun Neck MER552WSC

Water cooled for 550A, Swan Neck Angle 45°, for 0.8 - 2.8 wire

Item number: 120595  
 Packing unit: 1



## PRODUCT DESCRIPTION

Water cooled for 550A, Swan Neck Angle 45°, for 0.8 - 2.8 wire

## TECHNICAL CHARACTERISTICS

Wire (mm):	0.8 - 2.8
Bending angle (°):	30
Max. current CO2 (A):	550
Duty Cycle CO2:	100
Max. current argon mixed gas (A):	380
Duty Cycle Argon mixed gas (%):	100
Cooling:	Water
Suitable:	MER552WSC

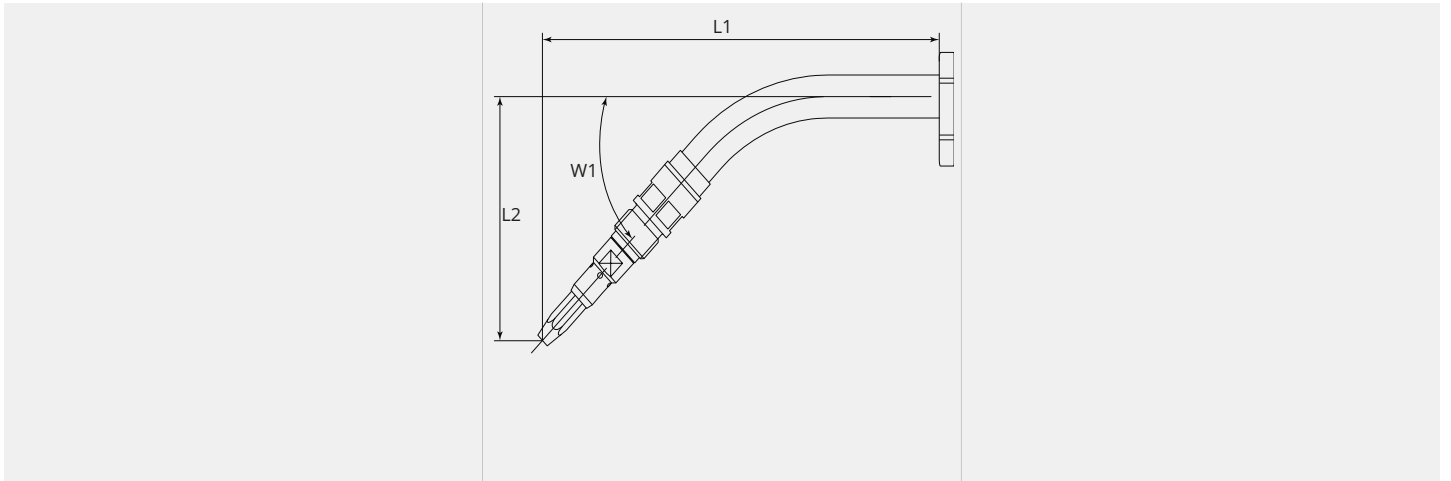
**DIMENSIONAL DRAWING****DIMENSIONAL DRAWING**

<b>L1 (mm):</b>	348.1
<b>L2 (mm):</b>	42.3
<b>W1 (°):</b>	30.0