

MIG/MAG Welding Gun Neck MER652WSC

Water cooled for 650A, Swan Neck Angle 20°, for 0.8 - 3.2 wire

Item number: 117583

Packing unit: 1



PRODUCT DESCRIPTION

Water cooled for 650A, Swan Neck Angle 20°, for 0.8 - 3.2 wire

TECHNICAL CHARACTERISTICS

Wire (mm):	0.8 - 3.2
Bending angle (°):	20
Max. current CO2 (A):	650
Duty Cycle CO2:	100
Max. current argon mixed gas (A):	400
Duty Cycle Argon mixed gas (%):	100
Cooling:	Water
Suitable:	MER652WSC

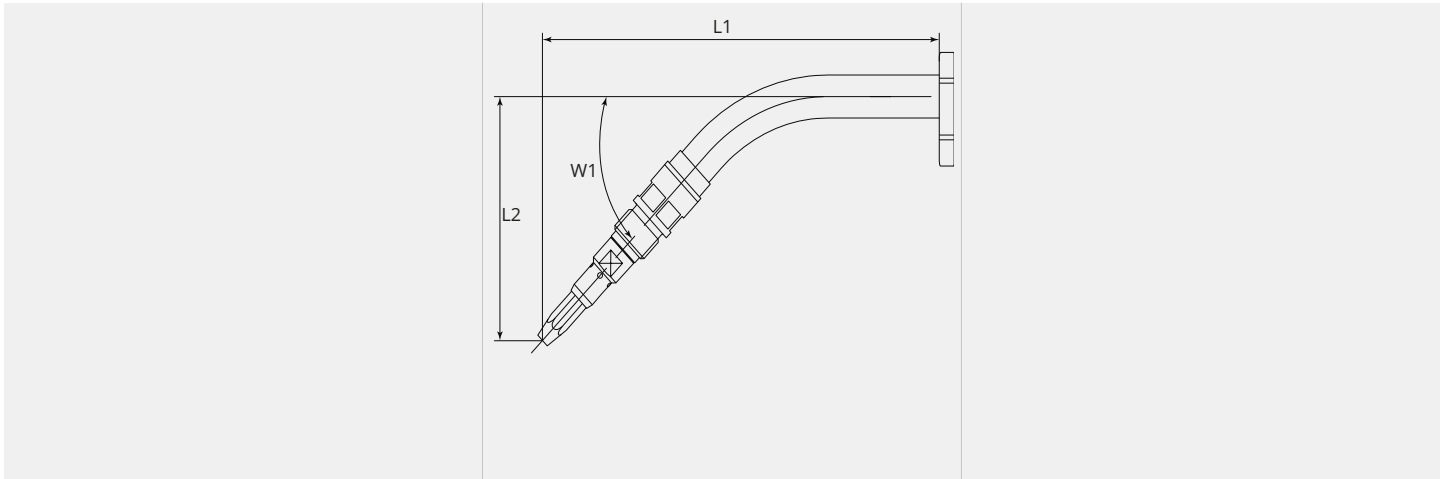
DIMENSIONAL DRAWING**DIMENSIONAL DRAWING**

L1 (mm):	227.7
L2 (mm):	51.6
W1 (°):	20.0