

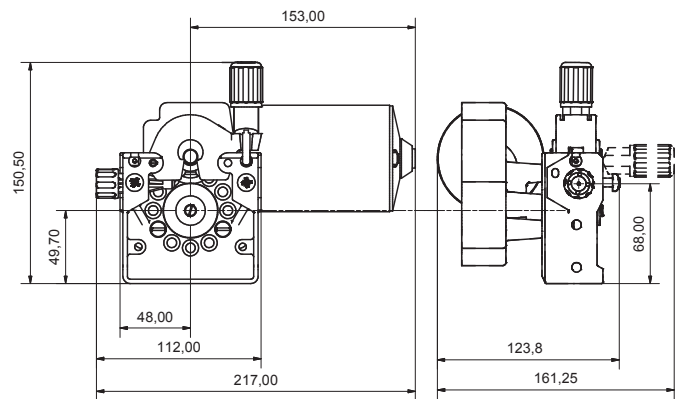

SERIES ME2500 2-ROLL 40mm WIRE DRIVE SYSTEM



Technical Data:

Drive Mechanism:	1 Drive Pinions / 2 Drive Pinions Geared
Pressure Arm:	Aluminium / Glass Fibre Reinforced Plastic (GRP)
Feedplate:	Aluminium
Rolls:	40mm
Motor Positions:	9

Type	Drive Mechanism	Pressure Arm	Feed Roll Class	Item no.
MESR 2520-40	1-Roll Driven	GRP Pressure-Arm / side release	with Keyway	102300*
MEFR 2520-40	1-Roll Driven	GRP Pressure-Arm / front release	with Keyway	102100*
MEFR 2521-40 Auto-Lift	1-Roll Driven	Aluminium Pressure-Arm Auto-Lift / front release	with Keyway	102150*
MEFR 2522-40 Auto-Lift	2-Roll Driven Geared	Aluminium Pressure-Arm Auto-Lift / front release	Standard	102200*
MEFR 2522-40 T.B.G. Auto-Lift	2-Roll Driven Geared	Aluminium Pressure-Arm Auto-Lift / front release	T.B.G.	102250*

*Wire Drive System supplied complete, less Motor | T.B.G. (Top and Bottom Groove) Feed Rolls



Motor Options:

Type	Voltage [V]	Drive [rpm]	Torque [Nm] 60% Cycle	Torque [Nm] continuous operation	Item no.
KSV 4030-182	24	200	3.0	2.0	80024
KSV 4030-186	42	200	3.0	2.0	80025
KSV 5035-484	24	160	1.5	1.0	80023
KSV 5035-483	24	200	3.5	2.0	80037
KSV 5035-486	42	230	3.5	2.0	80039
KSV 5035-389 Tacho	24	200	3.5	2.0	80042

other motors on request



Feed Rolls 37mm:

Type	Groove	Wire Ø	Item no. with Keyway	Item no. Standard	Item no. T.B.G.
Feed Roll V Groove 0.6 + 0.8mm	V	0.6 + 0.8mm	140001	140101	-
Feed Roll V Groove 0.8 + 1.0mm	V	0.8 + 1.0mm	140002	140102	-
Feed Roll V Groove 1.0 + 1.2mm	V	1.0 + 1.2mm	140003	140103	140201
Feed Roll V Groove 1.2 + 1.6mm	V	1.2 + 1.6mm	140004	140111	140202
Feed Roll U Groove 0.8 + 0.9mm A	U	0.8 + 0.9mm	140005	140104	-
Feed Roll U Groove 1.0 + 1.2mm A	U	1.0 + 1.2mm	140006	140105	140203
Feed Roll U Groove 1.2 + 1.6mm A	U	1.2 + 1.6mm	140007	140106	140204
Feed Roll U Groove 2.4 + 3.2mm A	U	2.4 + 3.2mm	140008	140107	140212
Feed Roll V Groove 1.0 + 1.2mm knurled	V knurled	1.0 + 1.2mm	-	-	140205
Feed Roll V Groove 1.0/1.2 + 1.4/1.6mm knurled	V knurled	1.0/1.2 + 1.4/1.6mm	140009	140108	-
Feed Roll V Groove 1.4 + 1.6mm knurled	V knurled	1.4 + 1.6mm	-	-	140206
Feed Roll V Groove 1.4/1.6 + 2.0/2.4mm knurled	V knurled	1.4/1.6 + 2.0/2.4mm	140010	140109	-

other feed rolls see catalogue feed rolls or on request | T.B.G. (Top and Bottom Groove)

Mechafin AG
 Chrummacherstr. 3 | CH-8954 Geroldswil | Switzerland
 Telephone +41 44 749 30 60 | Facsimile +41 44 749 30 70
 Mail info@mechafin.ch | Web www.mechafin.com

Mechafin Ltd
 Leigh Street | High Wycombe | Buckinghamshire | HP11 2QU UK
 Telephone +44 1494 441 110 | Facsimile +44 1494 473 049
 Mail enquiries@mechafin.co.uk | Web www.mechafin.com

All descriptions included in this catalogue are correct at the time of printing and may be subject to change and alternation from time to time. The contents used in this catalogue are property of Mechafin AG. This means, they are protected copyrights and/or trademarks or otherwise protected by ownership law.