



ME552WSC WATER SUPER-COOLED WELDING TORCHES MIG/MAG 550 Amp.



These torches are characterized by the following features:

- Ergonomic and technically advanced, 100% reliable
- Globally recognized using top quality
- New ergonomically shaped handles for best accessibility and fatigue-free work
- Handle with ball joint for motion flexibility - excellent handling
- Optimal torch cooling over long periods
- Best ignition even with thin wires
- Versatility due to the Euro Central Adapter System
- Different handles available upon request
- Swan Neck in 180° / 60° / 45°

Model	ME552WSC
Maximum current CO ₂	550 A
Duty Cycle CO ₂	80%
Maximum current Argon R.G.M.	450 A
Duty Cycle Argon	80%
Wire Ø	0.8 - 2.8 mm

Type	Item no. - 3.0m	Item no. - 3.5m	Item no. - 4.0m	Item no. - 4.5m
ME552WSC-N Spring Pins	116775	116776	116777	116778

Different lengths available upon request

Replacement Parts:

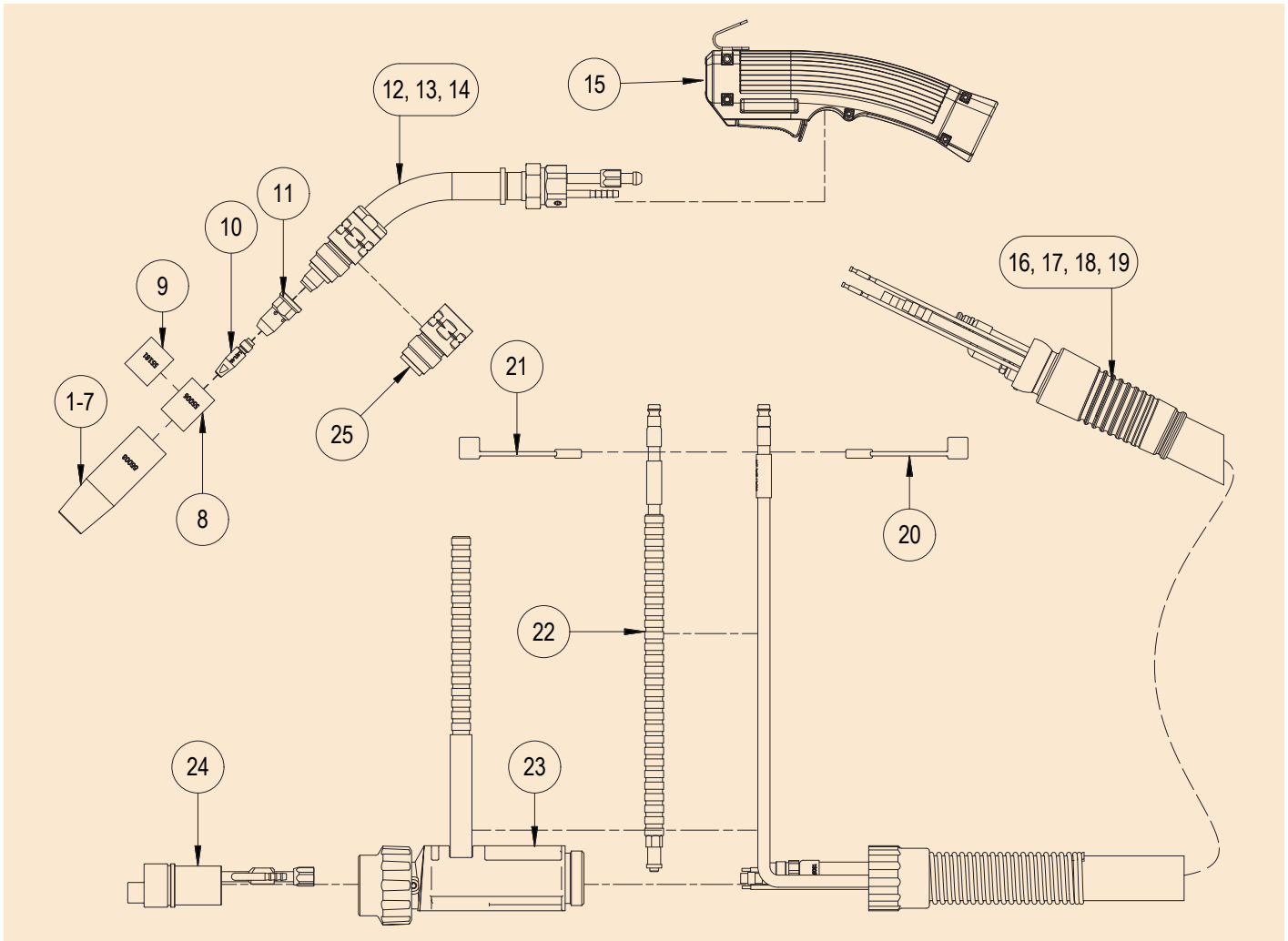

Pos.	Item no.	Description	pcs.
1	55003	Nozzle spray HD ID 17mm	1
2	55026	Nozzle spray HD short	1
3	55005	Nozzle spray small bore ID 10.5mm	1
4	55008	Nozzle pulse HD ID 17mm	1
5	55004	Nozzle spot HD	1
6	55009	Nozzle spray HD long	1
7	55011	Nozzle spray HD short	1
8	55006	Nozzle insulator Ø 22 x 19 L = 30.5	5
9	55181	Nozzle insulator Ø 22 x 19 L = 26	5
10	57840	Contact tip M8 copsil 1.6 / 1.4 aluminium round	10
11	55086	Gas diffuser ME552 WSC	5
12	55180	Swan neck ME552 WSC - 45° compl.	1
13	55185	Swan neck ME552 WSC - 60° compl.	1

Pos.	Item no.	Description	pcs.
14	55182	Swan neck ME552 WSC - 180° compl.	1
15 ¹	117693	Handle kit size 4-6 with ball joint	1
16	117553	Hose cable assembly 552WSC, spring pins, ball joint, 3.0m	1
17	117554	Hose cable assembly 552WSC, spring pins, ball joint, 3.5m	1
18	117555	Hose cable assembly 552WSC, spring pins, ball joint, 4.0m	1
19	117556	Hose cable assembly 552WSC, spring pins, ball joint, 4.5m	1
20	115822	Water cap, blue	1
21	115823	Water cap, red	1
22	76054	Water outlet hose compl.	1
23	117695	Central adapter support, water cooled, kit	1
24	57341	2-pin central adapter M12 x 1. compl. spring pins	1
25	55188	Service kit swan neck ME552WSC -MER552WSC	1

¹ = for other handle kits refer to data sheet: Handle kits

Gas Diffuser



55086 M8

Liners Hard Wire



57195 - 3.0m 0.8 - 1.2 blue, steel wire
57196 - 3.5m 0.8 - 1.2 blue, steel wire
57197 - 4.0m 0.8 - 1.2 blue, steel wire
57198 - 4.5m 0.8 - 1.2 blue, steel wire
57261 - 3.0m 1.4 - 2.0 red, steel wire
57262 - 3.5m 1.4 - 2.0 red, steel wire
57263 - 4.0m 1.4 - 2.0 red, steel wire
57264 - 4.5m 1.4 - 2.0 red, steel wire

57281 - 3.0m 1.2 - 1.4 grey, steel wire
57282 - 3.5m 1.2 - 1.4 grey, steel wire
57283 - 4.0m 1.2 - 1.4 grey, steel wire
57284 - 4.5m 1.2 - 1.4 grey, steel wire
57381 - 3.0m 2.0 - 3.2 yellow, steel wire
57382 - 3.5m 2.0 - 3.2 yellow, steel wire
57383 - 4.0m 2.0 - 3.2 yellow, steel wire
57384 - 4.5m 2.0 - 3.2 yellow, steel wire

Liners Soft Wire



57155 - 3.0m 0.8 - 1.0 black, aluminium wire
57156 - 3.5m 0.8 - 1.0 black, aluminium wire
57157 - 4.0m 0.8 - 1.0 black, aluminium wire
57158 - 4.5m 0.8 - 1.0 black, aluminium wire
57250 - 3.0m 1.2 - 2.0 red, aluminium wire
57251 - 3.5m 1.2 - 2.0 red, aluminium wire
57252 - 4.0m 1.2 - 2.0 red, aluminium wire
57253 - 4.5m 1.2 - 2.0 red, aluminium wire

57200 - 3.0m 1.0 - 1.2 blue, aluminium wire
57201 - 3.5m 1.0 - 1.2 blue, aluminium wire
57202 - 4.0m 1.0 - 1.2 blue, aluminium wire
57203 - 4.5m 1.0 - 1.2 blue, aluminium wire
114706 - 3.0m 2.0 - 3.2 yellow, aluminium wire
114707 - 3.5m 2.0 - 3.2 yellow, aluminium wire
114708 - 4.0m 2.0 - 3.2 yellow, aluminium wire
114709 - 4.5m 2.0 - 3.2 yellow, aluminium wire

Type

Contact Tips











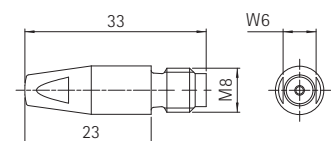
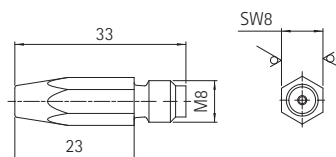



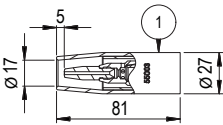

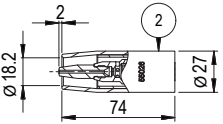
Contact Tip M8 hexagonal (pure copper)
MOQ = 10 pcs.

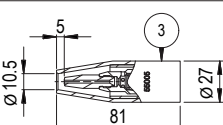
57800 - M8 0.8 hexagonal
57801 - M8 0.9 hexagonal
57802 - M8 1.0 / 0.8 aluminium hexagonal
57803 - M8 1.2 / 1.0 aluminium hexagonal
57804 - M8 1.4 / 1.2 aluminium hexagonal
57805 - M8 1.6 / 1.4 aluminium hexagonal
57834 - M8 1.8 / 1.6 aluminium hexagonal
57806 - M8 2.0 / 1.8 aluminium hexagonal
57807 - M8 2.4 / 2.0 aluminium hexagonal
57813 - M8 2.8 / 2.4 aluminium hexagonal

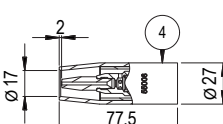
Contact Tip M8 round, copsil (copper-silver)
MOQ = 10 pcs.

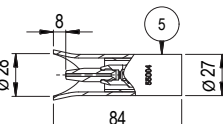
57835 - M8 copsil 0.8 round
57836 - M8 copsil 0.9 round
57837 - M8 copsil 1.0 / 0.8 aluminium round
57838 - M8 copsil 1.2 / 1.0 aluminium round
57839 - M8 copsil 1.4 / 1.2 aluminium round
57840 - M8 copsil 1.6 / 1.4 aluminium round
-
57841 - M8 copsil 2.0 / 1.8 aluminium round
57842 - M8 copsil 2.4 / 2.0 aluminium round
57843 - M8 copsil 2.8 / 2.4 aluminium round

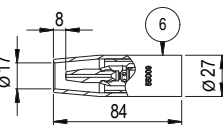

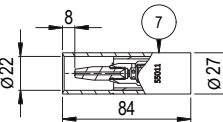
	Pos.	Item no.	Description
 	1	55003	Nozzle spray HD ID 17mm
 	2	55026	Nozzle spray HD short
 	3	55005	Nozzle spray small bore ID 10.5mm
 	4	55008	Nozzle pulse HD ID 17mm
 	5	55004	Nozzle spot HD
 	6	55009	Nozzle spray HD long
 	7	55011	Nozzle spray HD short

- Nozzle insulator item no.: 55006
use for Gas Nozzle item no.: 55003, 55026, 55008, 55004, 55009, 55011

- Nozzle insulator item no.: 55181
use for Gas Nozzle item no.: 55005