



ME300A HEAVY DUTY GAS COOLED WELDING TORCHES MIG/MAG 300 Amp



These torches are characterized by the following features:

- Ergonomic and technically advanced, 100% reliable
- Globally recognized top quality
- New ergonomically shaped handles for best accessibility and fatigue-free work
- Handle with ball joint for motion flexibility - excellent handling
- Optimal torch cooling over long periods
- Best ignition even with thin wires
- Versatility due to the Euro Central Adapter System
- Different handles available upon request
- Swan Neck in 180° / 45°

Model	ME300A
Maximum current CO ₂	300 A
Duty Cycle CO ₂	60%
Maximum current Argon R.G.M.	185 A
Duty Cycle Argon	60%
Wire Ø	0.6 - 1.4 mm

Type	Item no. - 3.0m	Item no. - 3.5m	Item no. - 4.0m	Item no. - 4.5m
ME300A-N Spring Pins	116711	116712	116713	116714

Different lengths available upon request

Replacement Parts:

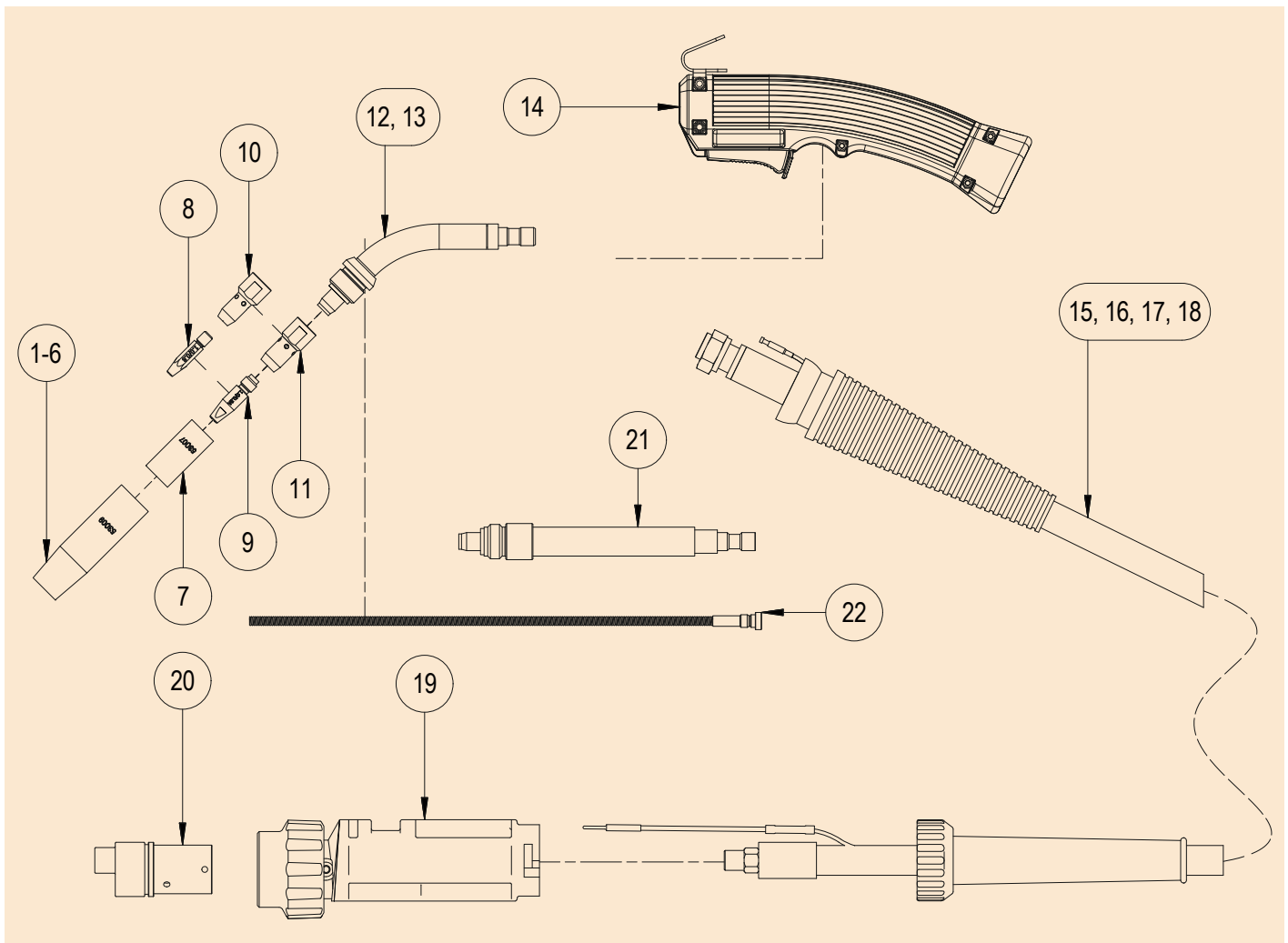

Pos.	Item no.	Description	pcs.
1	53009	Nozzle spray HD	1
2	53004	Nozzle dip, long conical	1
2a	53157	Nozzle dip, long conical *	1
3	53003	Nozzle dip, short conical	1
3a	53156	Nozzle dip, short conical *	1
4	53015	Nozzle spray HD short	1
5	53005	Nozzle parallel	1
6	53006	Nozzle spot	1
7	53001	Spatter protection Ø16.9 x 14.5 L = 36	5
8	57603	Contact tip M6 1.0 / 0.8 hexagonal	10
9	57837	Contact tip M8 copsil 1.0 / 0.8 aluminium round	10
10	53002	Gas diffuser M6 ME300A-ME350A	5
11	53008	Gas diffuser M8 ME300A-ME350A	5

Pos.	Item no.	Description	pcs.
12	53000	Swan neck ME300A - 45° compl.	1
13	53010	Swan neck ME300A - 180° compl.	1
14 ¹	117692	Handle kit size 1-3 with ball joint	1
15	117377	Hose cable assembly ME300A, spring pins, ball joint, 3.0m	1
16	117378	Hose cable assembly ME300A, spring pins, ball joint, 3.5m	1
17	117379	Hose cable assembly ME300A, spring pins, ball joint, 4.0m	1
18	117380	Hose cable assembly ME300A, spring pins, ball joint, 4.5m	1
19	117757	Central adapter support, gas cooled, kit	1
20	57113	2-Pin central adapter M12 x 1 compl. spring pins	1
21	117916	Swan neck ME300A Flex	1
22	117980	Liner ID2.5 with nipple M7	1

¹ = for other handle kits refer to data sheet: Handle kits

* no plating

Gas Diffuser

53002 M6

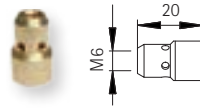

53008 M8

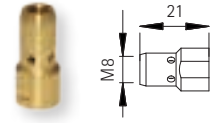

Liners Hard Wire



- 57151 - 3.0m 0.6 - 0.8 black, steel wire
- 57152 - 3.5m 0.6 - 0.8 black, steel wire
- 57153 - 4.0m 0.6 - 0.8 black, steel wire
- 57154 - 4.5m 0.6 - 0.8 black, steel wire
- 57275 - 3.0m 1.2 - 1.4 grey, steel wire
- 57276 - 3.5m 1.2 - 1.4 grey, steel wire
- 57277 - 4.0m 1.2 - 1.4 grey, steel wire
- 57278 - 4.5m 1.2 - 1.4 grey, steel wire

- 57191 - 3.0m 0.8 - 1.2 blue, steel wire
- 57192 - 3.5m 0.8 - 1.2 blue, steel wire
- 57193 - 4.0m 0.8 - 1.2 blue, steel wire
- 57194 - 4.5m 0.8 - 1.2 blue, steel wire

Liners Soft Wire



- 57155 - 3.0m 0.8 - 1.0 black, aluminium wire
- 57156 - 3.5m 0.8 - 1.0 black, aluminium wire
- 57157 - 4.0m 0.8 - 1.0 black, aluminium wire
- 57158 - 4.5m 0.8 - 1.0 black, aluminium wire
- 57250 - 3.0m 1.2 - 2.0 red, aluminium wire
- 57251 - 3.5m 1.2 - 2.0 red, aluminium wire
- 57252 - 4.0m 1.2 - 2.0 red, aluminium wire
- 57253 - 4.5m 1.2 - 2.0 red, aluminium wire

- 57200 - 3.0m 1.0 - 1.2 blue, aluminium wire
- 57201 - 3.5m 1.0 - 1.2 blue, aluminium wire
- 57202 - 4.0m 1.0 - 1.2 blue, aluminium wire
- 57203 - 4.5m 1.0 - 1.2 blue, aluminium wire

Type

Contact Tips



Contact Tip M6 hexagonal (pure copper)
MOQ = 10 pcs.

- 57600 - M6 0.6 hexagonal
- 57601 - M6 0.8 hexagonal
- 57602 - M6 0.9 hexagonal
- 57603 - M6 1.0 / 0.8 hexagonal
- 57604 - M6 1.2 / 1.0 hexagonal
- 57605 - M6 1.4 / 1.2 hexagonal

Contact Tip M6 round, cospil (copper-silver)
MOQ = 10 pcs.

- 57950 - M6 cospil 0.6 round
- 57951 - M6 cospil 0.8 round
- 57952 - M6 cospil 0.9 round
- 57953 - M6 cospil 1.0 round
- 57954 - M6 cospil 1.2 round









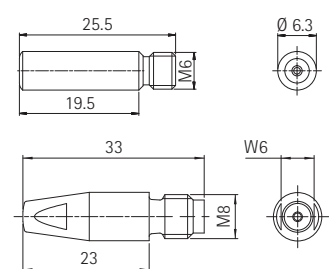
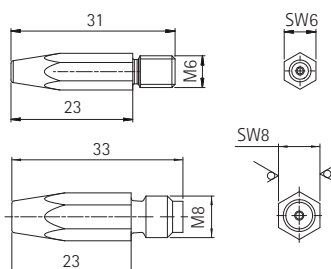

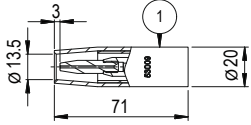

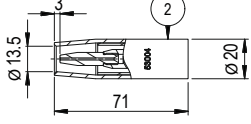

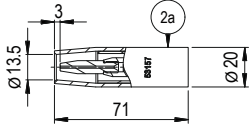
Contact Tip M8 hexagonal (pure copper)
MOQ = 10 pcs.

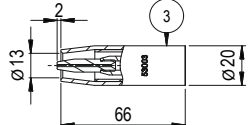
- 57800 - M8 0.8 hexagonal
- 57801 - M8 0.9 hexagonal
- 57802 - M8 1.0 / 0.8 aluminium hexagonal
- 57803 - M8 1.2 / 1.0 aluminium hexagonal
- 57804 - M8 1.4 / 1.2 aluminium hexagonal

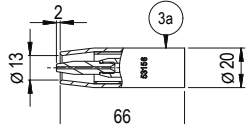
Contact Tip M8 round, cospil (copper-silver)
MOQ = 10 pcs.

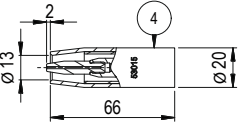
- 57835 - M8 cospil 0.8 round
- 57836 - M8 cospil 0.9 round
- 57837 - M8 cospil 1.0 / 0.8 aluminium round
- 57838 - M8 cospil 1.2 / 1.0 aluminium round
- 57839 - M8 cospil 1.4 / 1.2 aluminium round

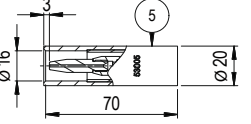

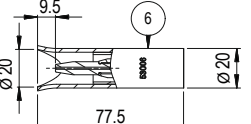
	Pos.	Item no.	Description
 	1	53009	Nozzle spray HD
 	2	53004	Nozzle dip, long conical
 	2a	53157	Nozzle dip, long conical *
 	3	53003	Nozzle dip, short conical
 	3a	53156	Nozzle dip, short conical *
 	4	53015	Nozzle spray HD short
 	5	53005	Nozzle parallel
 	6	53006	Nozzle spot

* no plating